

Towards an Inclusive Education framework for India

*An analysis of the rights of
children with disabilities and the
RTE Act*

Prianka Rao
Shreya Shrivastava
Tanushree Sarkar

April 2020

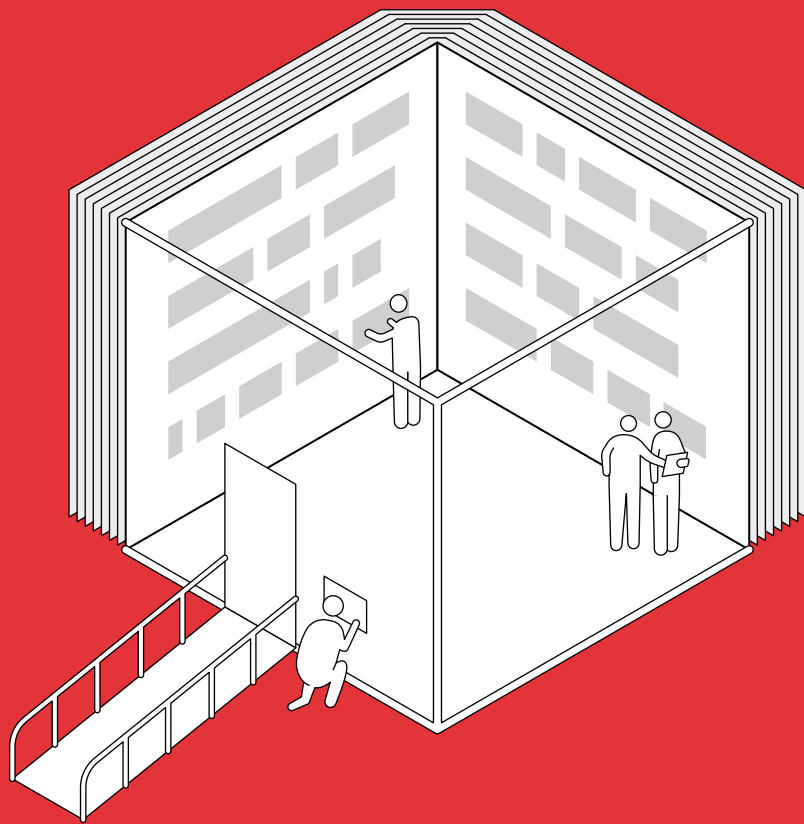

This report is an independent, non-commissioned piece of work by the Vidhi Centre for Legal Policy, an independent think-tank doing legal research to help make better laws.

About the Authors

Prianka Rao was a Senior Resident Fellow at the Vidhi Centre for Legal Policy.

Shreya Shrivastava is a Research Fellow at the Vidhi Centre for Legal Policy.

Tanushree Sarkar was an Associate Fellow with the Vidhi Centre for Legal Policy.

Acknowledgements

This Report is part of the Kotak Karma Vidhi Inclusive Education Programme. It has been supported by Kotak Mahindra Bank Foundation.

The authors would like to thank Amar Jain and Rahul Bajaj for peer reviewing the report.

The authors would like to thank Anjela Taneja, Armaan Ali, Kim D'Souza, Naina Seth, Namrata Mukherjee, Rati Misra, Svetlana Correya and Syamala G for their valuable inputs to the Report. The authors would like to thank Vidhi interns Cheta Sheth, Gatha G Namboothiri, Husain Aanis Khan, Kadambari Agarwal, Kriti Sharma, Milind Khemka, Mugdha Mohapatra, Nivedhitha Kalyanaraman, Parimal Kashyap, Prannv Dhawan, Sagarika Parab, Saumya Jaju, Shubhra Baghel, Surabhi Kulkarni, Tala Pesigan, Tia Mathew and Vivek Singh for their research assistance.

The authors would like to thank partner organisations Action for Autism, Akanksha Foundation, Amar Jyoti Charitable Trust, Bethany Society, Ferrando Speech and Hearing Centre, Jai Vakeel Foundation, Leadership for Equity, National Centre for Promotion of Employment of Disabled People, National Coalition for Education, Samaaveshi Pathshaala, Shishu Sarothi and SwaTaleem Foundation for supporting the field study for the report.

Contents

Introduction	01		
I • 05		II • 19	
Designing For Delivery of Inclusive Education		Entering the Education System	
1.1 An overview of the governance structure	05	2.1 Identification	19
1.1.1 Role of the Central Ministries		2.2 Certification	20
1.1.2 Design of the Sarva Shiksha Abhiyan		2.2.1 Role of schools and teachers in facilitating disability certificate	
1.2. Regulation of various school models	07	2.3 Benefits	23
1.2.1 Government/neighbourhood schools		2.3.1 Transport facilities	
1.2.2 Private unaided and specified schools		2.3.2 Aids and appliances	
1.2.3 Special schools		2.3.3 Financial Assistance	
1.2.4 Home based education			
1.2.5 School models and Parental choice			
III • 27		IV • 34	
Aspiring to learning as a child with disability		Reimaging Inclusive Education in the RTE Act	
3.1 Teachers	27	4.1 Making inclusive education the norm; clarifying the models of special schools and home based education	35
3.1.1 Qualification requirements		4.2 Defining terms related to categories of disability	37
3.1.2 On going teacher training and upskilling		4.3 Reassigning the governance of special schools to the MHRD	38
3.1.3 Special educators		4.4 Rethinking teacher role and training	39
3.1.4 Working conditions of teachers			
3.2 Curriculum and pedagogy	30		
3.3 Infrastructure	32		
Annexure 1	42	Annexure 2	43
Table 1: Details of stakeholders interviewed across different states		Proposed Amendments to the Right of Children to Free and Compulsory Education Act, 2009 to guarantee a right to inclusive education	

Introduction

The right to education is an integral facet of the guarantee of equal rights for children with disabilities and their social inclusion. Until 2002, the objective of universalisation of elementary education was recognised as a Directive Principle of State Policy in the Constitution of India. Directive Principles are not justiciable rights, but lay down the policy priorities for any government. In 2002, the provision of universal primary education was recognised as a Fundamental Right under Article 21A, thereby guaranteeing all children between the ages of 6-14, a justiciable right to free, compulsory primary education.¹

It was in furtherance of this constitutional mandate that the central government passed the Right of Children to Free and Compulsory Education Act, 2009 (RTE Act) to reinforce this right and the manner in which it would be operationalised. The RTE Act clarifies that the right to free and compulsory elementary education extends to all children, specifically defining and bringing children belonging to 'disadvantaged groups' within its ambit. The broad definition of 'children belonging to disadvantaged groups' includes children with disabilities. The RTE Act also recognises a separate category, 'a child with severe disability'.

In parallel, India's disability laws have also evolved, especially in light of India's obligations under the United Nations Convention on the Rights of Persons with Disabilities (UNCRPD). The now replaced Persons with Disabilities (Equal Opportunities, Protection of Rights and Full Participation) Act, 1995 (PWD Act, 1995) contained a chapter on the obligations of the government to "ensure that every child with a disability has access to free education

in an appropriate environment till he attains the age of eighteen years". Further, it also stated that the government must endeavour to integrate children with disabilities into "mainstream schools", while also allowing for the setting up of special schools for those requiring special education. With the passage of the Rights of Persons with Disabilities Act, 2016 ('RPWD Act'), the term 'inclusive education' has been given statutory backing. The RPWD Act defines inclusive education as "a system of education wherein students with and without disability learn together and the system of teaching and learning is suitably adapted to meet the learning needs of different types of students with disabilities." It also imposes an obligation on the government to take steps to ensure inclusive education. Despite the evolution of new legal standards, there are several inconsistencies between the RTE Act and the RPWD Act which have resulted in a contradictory and non-uniform legislative and regulatory framework for inclusive education. Since the RTE Act was enacted prior to the modification of the disability law framework, it appears to have carried forward the approach of "integration" as opposed to "inclusion" similar to the now repealed PWD Act, 1995. As Sharma and Deppeler² explain, integrated education emphasises the "student to fit in the system rather than the system to adapt", while inclusive education emphasises changes in system-level practices and policies to meet student needs.

Further, the scale of the problem surrounding access to quality education for children with disabilities is not just confined to the legal framework. Several researchers have documented the challenges of counting the number of disabled people in India.³ As per the 76th National Sample Survey from 2018,

¹ The Constitution (Eighty-sixth Amendment) Act, 2002.

² Umesh Sharma and Deppeler Joanne, 'Integrated Education in India: Challenges and Prospects' (2005) 25 Disability Studies Quarterly 1.

³ Roger Jeffrey and Nidhi Singal, 'Measuring Disability in India' (2008) 43 Economic & Political Weekly 22, Nenad Kostanjsek and others, 'Counting Disability: Global and National Estimation' (2013) 35 Disability and Rehabilitation 1065.

48% of disabled people are illiterate and only 62.9% of disabled people between the ages of 3 and 35 had ever attended regular schools. Meanwhile, only 4.1% of those not enrolled in regular schools had ever been enrolled in special schools. Disabled children rarely progress beyond primary school, and only 9% have completed higher secondary education.⁴ The 2011 Census estimates that there are 2.13 million children with a disability, of which 28% are not in school. Overall, children with disabilities are less likely to be in school and more likely to drop out of school.⁵

This report seeks to serve as a starting point for the identification of inconsistencies between various existing legal frameworks, and challenges to their implementation in different contexts.

Research Approach

The origins of this report may be traced back to an ongoing matter in the Supreme Court *Rajneesh Kumar Pandey & Ors. v. Union of India*,⁶ where Vidhi was an intervenor. During the course of this exercise, it became clear that the legislative framework for the right of children with disabilities to primary education is inconsistent and unclear. Hence, we began an internal textual harmonisation exercise between the RTE Act and the RPWD Act

However, a need was felt to go beyond the text of the law to examine some policy questions that require deeper engagement with various stakeholders. To this end, the second part of the study focused on gathering information from various stakeholders to understand their perspectives towards attaining inclusive education for children with disabilities. These stakeholders include parents, teachers, civil society organisations (CSO), and government officials from various departments. The study aimed to understand stakeholders' knowledge

of and access to provisions for the inclusive education for children with disabilities as per the RTE Act and the RPWD Act.

Research questions and design

We followed an exploratory case study design⁷ to address the experiences of varied stakeholders with respect to the provisions for inclusive education for children with disabilities under the RTE Act and the RPWD Act. The harmonisation process and the review of existing literature led us to identify five key domains of investigation. Each area of investigation attempted to unpack different aspects of the educational experiences of children with disabilities.

- 1. How are children defined as disabled?**
 - a. Identification of children with disabilities;
 - b. Certification of children with disabilities.
- 2. Where do children with disabilities go to school?**
 - a. Parent and school choice;
 - b. Access to and enrolment in educational institutions.
- 3. What kinds of support are available to children with disabilities?**
 - a. Barrier-free, disabled-friendly infrastructure;
 - b. Government benefits and resources;
 - c. Availability of aids and appliances.
- 4. What is the experience of children with disabilities in the school and in the classroom?**
 - a. Classroom environment;
 - b. Teaching strategies and pedagogy;
 - c. Curriculum and assessment.
- 5. What are societal understandings about children with disabilities?**
 - a. Beliefs about inclusive education;
 - b. Beliefs about disability.

⁴ The World Bank, 'People with Disabilities in India: From Commitment to Outcomes' (2007).

⁵ Parul Bakhshi, Ganesh M Babulal and Jean Francois Trani, 'Education of Children with Disabilities in New Delhi: When Does Exclusion Occur?' (2017) 12 PLoS ONE 1.

⁶ WP(C) 132/2016

⁷ Robert E Stake, Qualitative Case Studies in N. K. Denzin & Y. S. Lincoln (Eds.), *The Sage handbook of qualitative research* (SAGE 2005) p. 443-466

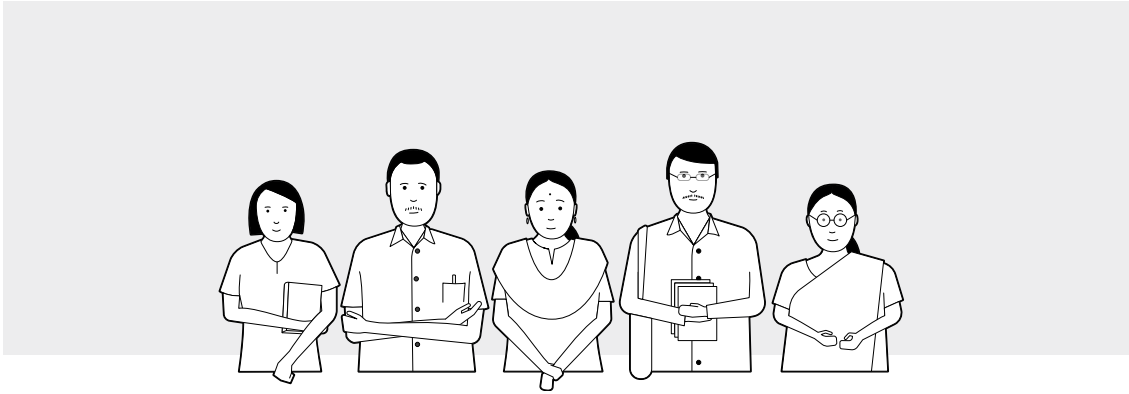

Field sites and participants

Field visits were conducted from June to August 2019. Field sites were selected in order to ensure diversity in demography and school type. Based on the availability of stakeholders and regional partners, Haryana, Maharashtra, Madhya Pradesh, Assam, and Meghalaya were selected as final sites for data collection. The lack of representation of a state from Southern India is acknowledged as a limitation of this study. Within each state, field visits were conducted either in several blocks of a particular district or across districts. The names of blocks and districts have not been provided to protect the anonymity of the participants. The total of 95 participants in the study included teachers, parents, special educators, resource persons,⁸ and officials at various levels and across government departments.

A comprehensive list of participants across states has been provided in Annexure 1 of this report.

Data collection and analysis

Except for in Assam and Meghalaya, at least one lawyer and one qualitative researcher were present at each of the field sites. In these two states, only one lawyer collected the data. Data collection happened through semi-structured interviews or focus groups depending on the availability of the participants. In some cases, telephonic interviews

were conducted. Interviews and focus groups were recorded with the participants' consent. However, only a few participants gave consent to record. Thus, the researcher took extensive field notes of the interviews, focus groups, and their observations. Field notes and transcripts were used as data and analysed using thematic analysis. Data was entered into Microsoft Excel. Notes were maintained during this process to generate an initial understanding of the data. The responses were coded in an inductive, data-driven manner.

⁸ Resource persons are itinerant teachers appointed under Sarva Shiksha Abhiyan to provide resource support to children with special needs.

Graphical Overview of Field Sites & Participants

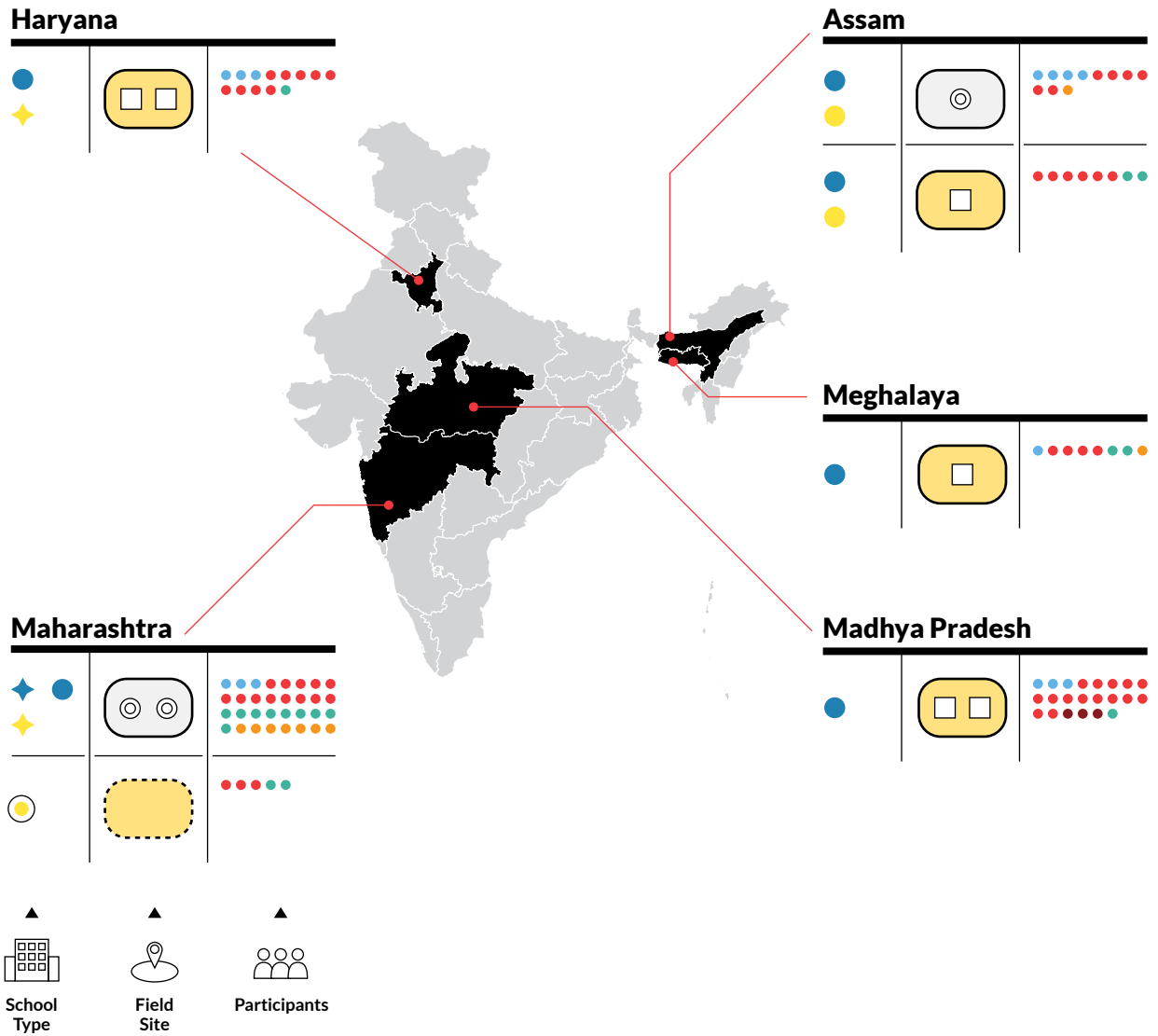

PARTICIPANTS	DEMOGRAPHY	SCHOOL TYPE
<ul style="list-style-type: none"> Government Officials Teachers/Educators Teacher Trainers Parents CSO members 	<ul style="list-style-type: none"> Urban Rural City Block For Example 2 Blocks in a District 	<ul style="list-style-type: none"> Government Private Regular Special Inclusive <p>For Example Private Special School</p>

I

Designing for Delivery of Inclusive Education

1.1 An overview of the governance structure

1.1.1 Role of the Central Ministries

Matters related to persons with disabilities fall within the purview of the Ministry of Social Justice and Empowerment (MSJE).⁹ The Department of Empowerment of Persons with Disabilities (DEPWD) under the MSJE is the nodal department responsible for the overall policy, planning and coordination of programmes for persons with disabilities. It has also been assigned the responsibility to implement the UNCRPD. However, the overall management and monitoring of the sectoral programmes in respect of persons with disabilities is the responsibility of the concerned central ministries, state governments and union territory administrations.¹⁰ The DEPWD has been allocated the responsibility to make schemes aimed

at social, educational and economic empowerment of persons with disabilities including supply of aids and appliances, scholarships, residential schools etc.¹¹ Still the overall management and monitoring of educational programs will continue to be the responsibility of the Ministry of Human Resource Development (MHRD) as it is the nodal ministry for education. While convergence is much needed between the two ministries for the implementation of inclusive education, it is not evident through inter-ministry coordination.¹² The two ministries continue to run parallel schemes and have parallel implementation frameworks for the education of children with disabilities without coming to terms with each other.

This was echoed in our conversations with stakeholders across states where government officials and special educators raised concerns over the lack of coordination between the efforts of the MHRD and the MSJE around the education

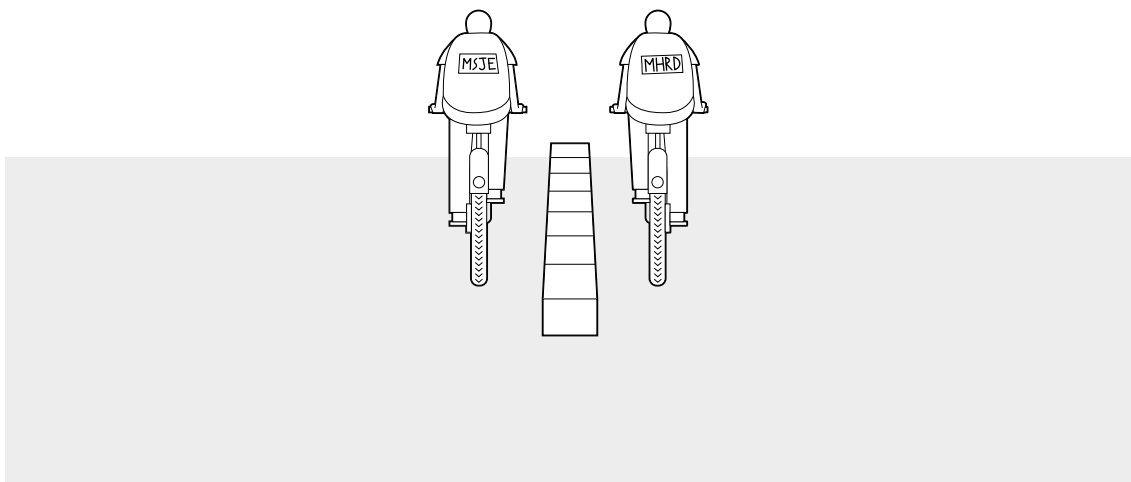

⁹ Allocation of Business Rules, 1961.

¹⁰ Entry 4, DEPWD, MSJE, Second Schedule, Allocation of Business Rules, 1961.

¹¹ Entry 5, DEPWD, MSJE, Second Schedule, Allocation of Business Rules, 1961.

¹² UNESCO, 'N FOR NOSE: State of the Education Report for India 2019 Children with Disabilities' <http://digitallibrary.in.one.un.org/TempPdfFiles/3793_1.pdf> accessed 9 January 2020.

of children with disabilities. As a member of a CSO stated, “this fight for turfism” between different government departments stems from a lack of clarity about who is responsible for the education of children with disabilities’. The absence of inter-departmental links has furthered the difficulty in obtaining reliable estimates of the number of children with disabilities enrolled in public and special schools.

However, there were some exceptions. In the case of urban Assam, government officials informed us that the departments of health, education and social welfare had good communication and coordination in organising medical camps, student enrolment in schools and the disability certification process. There were specific examples about the convergence of the National Rural Health Mission and the centrally sponsored scheme, the Sarva Shiksha Abhiyan, in rural Assam, which has helped in the allocation of health-related entitlements to children with disabilities. Convergence on issues of education, however, seems bleak. In most places, the links between MHRD and MSJE seemed to be *ad-hoc* or based on individual relationships between special schools and block level resource persons.

1.1.2 Design of the Sarva Shiksha Abhiyan

Sarva Shiksha Abhiyan (‘SSA’) has been operational since 2000 as an effort to universalise elementary education. It aims to provide universal education to children between the ages of 6 and 14 years. Some of the key interventions of the SSA included opening of new schools and alternative schooling facilities, in-service training and academic resource support for regular teachers, free textbooks, uniforms and support for improving learning achievement levels/ outcome.¹³ The SSA was started as a partnership between the central, state and local governments. It provided an opportunity for states to develop their own vision of elementary education. Hence, it was introduced as a framework within which states could

formulate detailed, specific guidelines keeping in view their specific social, economic and institutional contexts.¹⁴

One of the challenges within the SSA is the compartmentalisation of education for children with special needs (CWSN). The existing structure of the SSA has created a separate cadre responsible for ensuring access to quality education for CWSN. Across states, we noted several instances of teachers and educational administrators using this cadre to absolve themselves of the responsibility of caring for children with disabilities. Teachers believe that it is the responsibility of the resource person to teach children with disabilities in the classroom; head teachers call resource persons when it comes to admission of children with disabilities, and government officials find inclusive education to be “the most neglected SSA program. There is a separate budget, which is either underspent or spent in disorganised ways.” (Independent Consultant, SSA, Maharashtra)

With regard to the budget, government officials and special educators across states complained of the lack of funds, delay in receiving funds, or the reduction in funds towards the education of children with disabilities. Inadequate funding was described as a challenge with regard to parental awareness and community mobilisation, teacher training and allocation of resource persons. In addition to neglect in terms of funding, administrative neglect was observed in lack of monitoring and inadequate staffing in government special schools or inclusive education programs – there is a dearth of sign language experts and special educators across disability types.

Overall, there is a massive shortage of special educators, resource persons, teacher training faculty, and government teachers. We found a shortage of trained staff in District Institute of Education and Training (DIET) and Block Institute of Teacher Education (BITE) in Madhya Pradesh and Haryana respectively. There are few blocks

¹³ Sarva Shiksha Abhiyan Framework for Implementation: Based on the RTE Act, MHRD <https://seshagun.gov.in/sites/default/files/2019-05/SSA-Frame-work_0.pdf> accessed 9 January 2020.

¹⁴ Sarva Shiksha Abhiyan: Framework for Implementation Draft, MHRD, Government of India <<https://www.educationforallindia.com/SSA1.htm>> accessed 9 January 2020.

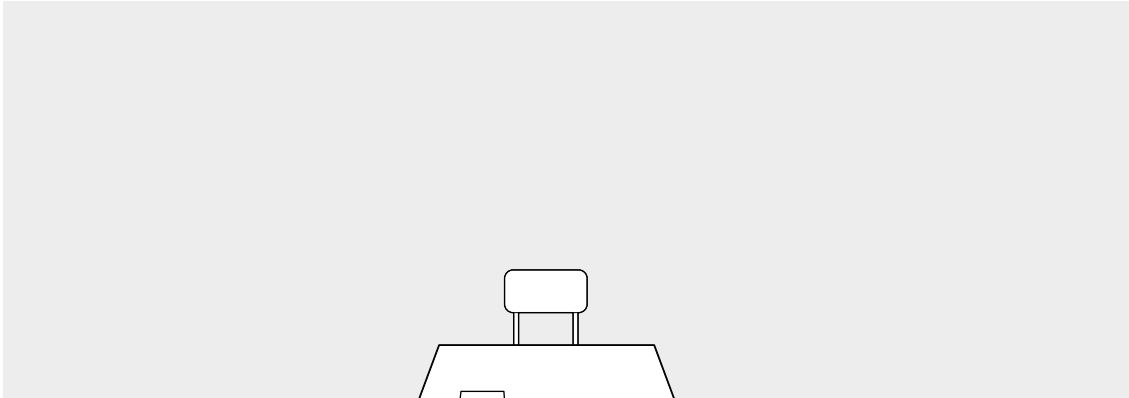

in Madhya Pradesh where the post of a block-level resource person is vacant. This shortage has persisted for over a decade, as previously reported by the World Bank in 2007. Each block is supposed to have 3 resource persons – one for visual impairment, one for hearing impairment, and one for intellectual disabilities. Not only is this inadequate based on the twenty-one disability categories under the RPWD Act, most blocks do not have the required number of resource persons who have expertise for each disability type. According to some special educators, one way to overcome this shortage is to have permanent positions for special educators or to appoint them as regular teachers, “Till the time special educators are considered to be teachers only for children with disabilities, this will not change, they have to be considered as people who are one important component in the entire inclusive education system” (Urban Assam).

1.2. Regulation of various school models

It is within this complex administrative set up that there are various types of schools providing elementary education. A ‘school’, as defined under the RTE Act,¹⁵ includes: (a) government and government-aided schools, (b) specified schools

run by autonomous organisations under the central government (such as Kendriya Vidyalayas and Navodaya Vidyalayas), (c) schools run by government departments directly (such as those run by defence and railways), (d) schools run by public sector undertakings, and (e) unaided schools (private). Government schools are run by the central, state or local governments. Aided schools are privately managed but receive grants-in-aid from central, state or local governments. Unaided schools (private) are non-profit entities established by trusts or as educational, charitable or religious societies registered under the Societies Registration Act, 1860, or State Acts. *Madarsas*, *vedic pathshalas* and educational institutes imparting religious instructions are exempt from the purview of the Act.¹⁶ Special schools which provide education and related services to children with disabilities are also outside the purview of the RTE Act’s definition of school.

Issues related to the regulation of educational institutions providing primary education have been revisited by the courts on multiple occasions. In *Society for Unaided Private Schools of Rajasthan v Union of India*,¹⁷ a three-judge bench of the Supreme while upholding the constitutional validity of the RTE Act held that the Act would apply to all government schools, aided schools (including

¹⁵ Section 2(n), RTE Act

¹⁶ The RTE Act amended in July 2012.

¹⁷ (2012) 6 SCC 1.h.

minority aided), specified category schools and unaided non-minority schools. However, the matter was then referred to a constitution bench of the Supreme Court, which held that if the RTE Act is made applicable to minority schools, aided or unaided, the right of the minorities under Article 30(1) of the Constitution will be abrogated. Thus, the RTE Act shall not apply to minority schools.¹⁸

The following sections will examine the regulation of different types of schools *vis-a-vis* the right to education of children with disabilities in greater detail, and present some salient observations from our field studies across India.

1.2.1 Government/neighbourhood schools

Right to education of children with disabilities recognised in the RTE Act:

The primary law that lays down the scope and obligations of government schools in relation to provision of primary education is the RTE Act. The RTE Act applies to all 'government schools', i.e. schools established, owned or controlled by the appropriate government or a local authority.¹⁹ Consequently, the obligation on such schools to provide free, compulsory, primary education extends to all children admitted there.²⁰ Further, the RTE Act clarifies that this guarantee of compulsory, primary education extends to *all* children up to the age of 14, including children with disabilities.²¹ Therefore, read together, it is clear that the RTE Act requires all such government schools in the country to not only admit but also provide free, compulsory, primary education to children with disabilities in the same manner as all other children. However, the RTE Act is silent on the manner in which such a level playing field for children with disabilities will be created to ensure that they are able to access the right to education in the same form and manner as all other children.

While the Act recognises such right of being admitted and provided compulsory and free education of children with disabilities, it does not go beyond the mere articulation of the right to specify how such an enabling environment should be created. For instance, it does not specify the use of the physical and digital infrastructure of the school, or having access to appropriate teaching techniques and other pedagogical tools for learning or having access to inclusive educational material which is accessible and available in appropriate formats to meet the specific needs of particular disabilities of children. The Schedule to the RTE Act, which specifies norms and standards for schools, includes that all-weather buildings must provide barrier free access.²² Nowhere else in the Act is there any mention of specific provisions for children with disabilities.

It may be argued that the SSA contains specific provisions in relation to children with disabilities and their access to primary education. However, the SSA is a centrally sponsored scheme, and unlike the RTE Act, which is a legislation, does not create statutory rights for children with disabilities.

Duties on government to provide inclusive education specified in the RPWD Act:

The RPWD Act, 2016 is not the primary statute for the recognition and regulation of compulsory, primary education in India. Despite this, it lays down a more specific list of duties for all educational institutions funded or recognised by the government to provide inclusive education, which includes:²³

- i. admit them without discrimination and provide education and opportunities for sports and recreation activities equally with others;
- ii. make building, campus and various facilities accessible;
- iii. provide reasonable accommodation according to the individual's requirements;

¹⁸ Archana Mehendale, Rahul Mukhopadhyay, Annie Namala, 'Right to Education and Inclusion in Private Unaided Schools: An Exploratory Study in Bengaluru and Delhi' (2015) 50(7) EPW.

¹⁹ Section 2(n)(i), RTE Act.

²⁰ Section 12(1)(a), RTE Act.

²¹ Section 2 (ee), RTE Act.

²² Item 2 (ii), the Schedule, RTE Act.

²³ Section 16, RPWD Act.

- iv. provide necessary support individualised or otherwise in environments that maximise academic and social development consistent with the goal of full inclusion;
- v. ensure that the education to persons who are blind or deaf or both is imparted in the most appropriate languages and modes and means of communication;
- vi. detect specific learning disabilities in children at the earliest and take suitable pedagogical and other measures to overcome them;
- vii. monitor participation, progress in terms of attainment levels and completion of education in respect of every student with disability;
- viii. provide transportation facilities to the children with disabilities and also the attendant of the children with disabilities having high support needs.

Consequently, while the rights giving provision is in the RTE Act, it does not contain any corresponding duties or obligations on the state to ensure the guarantee of such rights. Further, since the RTE Act continues to allude to the now replaced PWD Act, 1995, both in terms of the text and the values reflected, its guarantee of rights to children with disabilities to access primary education remains inadequate and discordant.

In practice, both rights and duties remain unrealised :

Based on interviews with parents, we observed that parents of children with disabilities select schooling options from a place of concern about their child's future economic prospects. Their primary concern was that schools should provide individualised care for their children based on the unique needs and requirements of the child's disability. Parents hope to select schools that provide holistic facilities around schooling, medical and therapeutic services. A key challenge, especially for parents experiencing poverty, is a lack of awareness about choices

available for their child's unique needs. Across states, parents with lower levels of education were less likely to be aware of government entitlements and how to access banking facilities to receive the entitlements. Schools don't always respect parental choice. Several parents who sent their children to special schools stated that they initially sent their child to a neighbourhood school. The school recommended the child be moved to a special school once they discovered the child's disability.

1.2.2 Private unaided and specified schools

The RTE Act extends to all private unaided schools as well as the specified category schools²⁴ as per the definition of 'school' under the Act.²⁵ The objectives of the RTE Bill, 2008 stated that *"the values of equality, social justice and democracy and the creation of a just and humane society can be achieved only through provision of inclusive elementary education to all. Provision of free and compulsory education of satisfactory quality to children from disadvantaged and weaker sections is, therefore, not merely the responsibility of schools run or supported by the appropriate governments, but also of schools which are not dependent on Government funds."*²⁶ This shows the intent of the legislators with respect to the inclusion of children with disabilities, who are identified as children belonging to disadvantaged groups and weaker sections in private unaided and specified category schools.²⁷

a. Obligation to provide free and compulsory education

The extent of responsibility of providing free and compulsory elementary education for private unaided and specified category schools is limited to children belonging to weaker sections and disadvantaged groups in the neighbourhood as per Section 12(1)(c) of the RTE Act. It mandates private unaided and specified category schools to reserve 25% of their class strength for children from weaker

²⁴ Section 2(p), RTE Act: "specified category", in relation to a school, means a school known as Kendriya Vidyalaya, Navodaya Vidyalaya, Sainik School or any other school having a distinct character which may be specified, by notification, by the appropriate government.

²⁵ Section 2(n), RTE Act.

²⁶ Statement and Objects, Right of Children to Free and Compulsory Education Bill, 2008 <https://www.prsindia.org/sites/default/files/bill_files/1229341892_The_Right_of_Children_to_Free_and_Compulsory_Education_Bill_2008.pdf> accessed 9 January 2020.

²⁷ Section 2(d), RTE Act.

sections and disadvantaged groups and provide free and compulsory elementary education till its completion.²⁸ Although the text of Section 12(1)(c) provides for the inclusion of children with disabilities in private unaided and specified schools, it does not necessarily benefit children with disabilities. Some of the possible reasons are:

- i. Clubbing of children with disabilities with other disadvantaged groups
- ii. Restrictive Neighbourhood criteria
- iii. Lack of enabling environment in private unaided and specified category schools

(i) Clubbing of children with disabilities with other disadvantaged groups

Children with disabilities were initially outside the scope of Section 12(1)(c). It was only after the amendment of the RTE Act in 2012, children with disabilities were defined as disadvantaged groups and brought under the purview of this provision. However, as they have been clubbed together with children from other disadvantaged groups, they have to compete with them for the 25% seats reserved under Section 12(1)(c). There is no mandate under the RTE Act for private unaided schools and specified schools to specifically admit a certain minimum percentage of children with disabilities under this provision. This gives a leeway to private unaided and specified schools to give preference to children without disabilities i.e. those from other disadvantaged groups in admissions. As a result,

children with disabilities are left out from the larger pool of disadvantaged children. An exploratory study conducted in 2015 in private unaided schools of Delhi and Bengaluru suggests that no children with disabilities were found to be admitted in the schools that were visited in both the cities.²⁹

Some states have taken steps in this regard by assigning a specific percentage to children with disabilities for reservation under Section(12)(1)(c). In Andhra Pradesh, for instance, the State RTE Rules prescribe that under Section 12(1)(c), 5% seats shall be assigned to HIV Aids, orphans and disabled children. Whereas, the Delhi Government has issued a notification reserving 3% seats from the total seats under EWS/DG category in private unaided schools for admission to children with disabilities.³⁰ This was done in pursuance of the Delhi High Court order in *Pramod Arora v. Hon'ble LG of Delhi*.³¹ However, as this notification mandates reservation of seats for children with disability only in private unaided schools, there is no clarity about such reservation in specified category schools. Further, a large number of seats remain vacant every year. Nearly 5000 seats reserved for children with disabilities remained vacant in private unaided schools for the session 2019-20 even after the reopening of the admission process multiple times.³² Last year too, around 1268 seats remained vacant, which were carried forward.³³ This shows that just reserving seats does not necessarily guarantee admission of children

²⁸ Section 12(1)(c), RTE Act.

²⁹ Archana Mehendale, Rahul Mukhopadhyay, Annie Namala, 'Right to Education and Inclusion in Private Unaided Schools: An Exploratory Study in Bengaluru and Delhi' (2015) 50(7) EPW. <<https://www.epw.in/journal/2015/7/special-articles/right-education-and-inclusion-private-unaided-schools.html>> accessed 17 October 2019.

³⁰ Delhi School Education (Free Seats for Students belonging to Economically Weaker Section and Disadvantaged Group) Amendment Order 2018, Directorate of Education, Government of NCT of Delhi <http://www.edudel.nic.in/upload/upload_2017_18/27068_73_dt_26072018.pdf> accessed 9 January 2020.

³¹ WPC 1225/2014.

³² 'Regarding instructions/guidelines for aspirants of the category of Children with Disabilities as defined in the Rights of Persons with Disabilities Act, 2016 to apply fresh online application against the remaining vacant seats at the entry level classes (Nursery, KG & Class-I) for the session 2019-20'; Circulars dated 23 September 2019 and 28 June 2019, Directorate of Education, Government of NCT of Delhi <http://edudel.nic.in/upload/upload_2019_20/11564_71_dt_24092019.PDF> <http://www.edudel.nic.in/upload/upload_2019_20/9487_9493_dt_18072019.pdf> accessed 9 January 2020.

³³ 'Regarding instructions/guidelines for aspirants of the category of Children with Disabilities as defined in the Rights of Persons with Disabilities Act, 2016 to apply fresh online application against the remaining vacant seats at the entry level classes (Nursery, KG & Class-I) for the session 2018-19'; Circular dated 20 December 2018, Directorate of Education, Government of NCT of Delhi <<http://it.delhigovt.nic.in/writereaddata/Cir2018523677.pdf>> accessed 9 January 2020.

with disabilities in private unaided schools. There are still irregularities in the implementation of this provision.³⁴

(ii) Neighbourhood criteria

The neighbourhood criteria attached to Section 12(1)(c) further restricts children with disability from exercising their choice as- *firstly*, most private unaided schools, especially in urban areas, are not necessarily located within a residential neighbourhood, and hence the probability of children residing within the rigid distance norms of neighbourhood accessing the provision is low in such schools.³⁵ *Secondly*, the school located in the neighbourhood, where a child with disability resides, may not be well equipped to reasonably accommodate the child. The Delhi High Court, in *Pramod Arora v. Hon'ble Lt. Governor of Delhi*, held that “the neighbourhood principle cannot prevail over the need to admit CWSN if in a given case, the school is equipped to deal with or handle some or one kind of disability (blindness, speech impairment, autism etc). The state therefore has to tailor appropriate policies to optimise admission of CWSN in those unaided schools, in the first instance, which are geared and equipped to deal with particular disabilities, duly balancing with the dictates of the neighbourhood criteria.”³⁶ As a result of this judgment, the Delhi Government in its circular reserving 3% seats for children with disabilities under the EWS/DG quota specified that such admissions shall be done without considering any neighbourhood criteria.³⁷ Other states, however, continue to follow the neighbourhood criteria for admission under Section 12(1)(c).

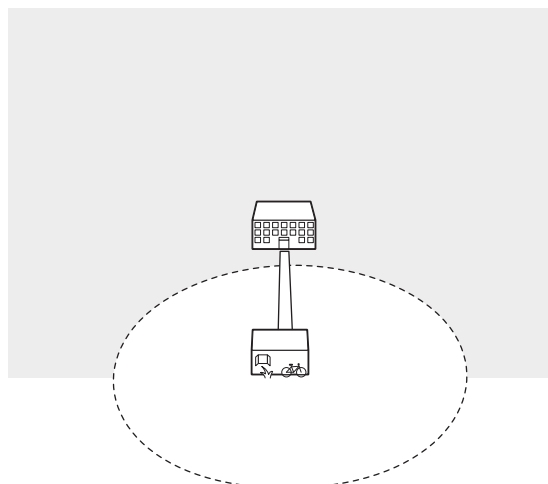

A 2015 government order issued in Uttar Pradesh stated that “the 25% reservation clause shall be applicable only in urban wards and not in rural wards. Those wards have to be identified where no government/board/aided schools exist and 25% reservation clause shall be applicable only in private unaided schools of such identified wards.”³⁸ This creates a hierarchy and prevents a child belonging to the disadvantaged or weaker section from the “choice” of seeking admission in a school of her preference especially when neither the enabling statute nor the enacted rule conceives of any such situation.³⁹ Further, it is completely inconsiderate of the choice of such children residing in rural wards. Recently, the Karnataka Government has also amended its RTE Rules to state that the obligation under Section 12(1)(c) of the RTE Act will not apply to a private school if a government or aided school

³⁴ Fareeha Iftikhar, '86.9% seats for kids with disabilities vacant in Delhi's pvt schools; DoE invites fresh applications' (*Hindustan Times*, 10 September 2019).

<<https://www.hindustantimes.com/cities/86-9-seats-for-kids-with-disabilities-vacant-in-delhi-s-pvt-schools-doe-invites-fresh-applications/story-B6ubQSuQv1Mqp4T9PSvliL.html>> accessed 23 October 2019.

³⁵ Archana Mehendale, Rahul Mukhopadhyay, Annie Namala, 'Right to Education and Inclusion in Private Unaided Schools: An Exploratory Study in Bengaluru and Delhi' (2015) 50(7) EPW.

<<https://www.epw.in/journal/2015/7/special-articles/right-education-and-inclusion-private-unaided-schools.html>> accessed 17 October 2019.

³⁶ *Pramod Arora v. Lt. Governor of Delhi and Ors.*, W.P. (C) 1225/2014, Delhi High Court.

³⁷ 'Regarding instructions/guidelines for aspirants of the category of Children with Disabilities as defined in the Rights of Persons with Disabilities Act, 2016 to apply online against the vacant seats at the entry level classes (Nursery, KG & Class-I) for the session 2018-19, Circular dated 26 July 2018, Directorate of Education, Government of NCT of Delhi <http://www.edudel.nic.in/upload/upload_2017_18/27068_73_dt_26072018.pdf> accessed 9 January 2020.

³⁸ Sushant Chandra, 'Derailing Right to Education in Uttar Pradesh' (2016) 51(11) EPW <<https://www.epw.in/journal/2016/11/reports-states/derailing-right-education-uttar-pradesh.html>> accessed 19 October 2019.

³⁹ *Ibid.*

is available in the neighbourhood.⁴⁰ In addition to the general repercussions, this dilution may have a huge impact specifically on children with disabilities as government aided schools might be available in the neighbourhood, but they may not be well equipped to accommodate children with disabilities. This affects the choice of children with disabilities to access possibly well equipped private unaided schools.

(iii) Lack of enabling environment

While the law aspires for inclusion of children with disabilities, often the lack of facilities and capacities of private unaided schools restricts the choice of these children. As recognised by the American Supreme Court in *Endrew F v. Douglas County School District RE-1*,⁴¹ “a student offered an educational program providing “merely more than de minimis” progress from year to year can hardly be said to have been offered an education at all. For children with disabilities, receiving instruction that aims so low would be tantamount to “sitting idly, awaiting the time when they were old enough to ‘drop out.’” While the Individuals with Disabilities Education Act in the US mandates an educational program, which enables a child to make progress appropriate in light of the child’s circumstances, the RTE Act does not go beyond an enabling provision for the admission of children with disabilities in private unaided schools. In reality, very little is invested in ensuring meaningful inclusion of these children at the school level after they have procured admission. Schools fail to translate the legislation’s original intent into practice.⁴² Therefore, it is important to turn next to the obligations are imposed under the law on private unaided schools to create an enabling environment and infrastructure for children with disabilities.

b. Obligation to provide an enabling environment to children with disabilities

As per the RTE Act, no private unaided school or specified school can be established or function without obtaining a certificate of recognition.⁴³ In order to get recognised, these schools have to follow norms and standards specified under the Schedule of the Act.⁴⁴ The recognition can be withdrawn if they fail to do so, and running of schools after the withdrawal of recognition may even lead to penal consequences.⁴⁵ This shows that these norms play an important role in ensuring that the schools fulfill basic minimum standards and this Schedule can possibly address the needs of children with disabilities in private unaided schools and specified category schools. However, it fails to mandate any specific norms with respect to children with disabilities except for barrier-free access, as discussed in the previous section. Annex 2 suggests amendments to the Schedule to address the needs of children with disabilities.

The RPWD Act casts certain obligations with respect to providing inclusive education on educational institutions⁴⁶ funded or recognised by the government, as discussed above. However, it does not define educational institutions and there is not enough clarity in the Act about its applicability to private unaided schools and specified category schools. As Section 16 of the Act uses the term “recognised” educational institutions, it can be inferred that it includes private unaided and specified category schools as recognised under the RTE Act. Further, this provision merely provides that “the appropriate government shall endeavour that all educational institutions funded or recognised by them provide inclusive education to the children

⁴⁰ ‘RTE : SC Issues Notice on Plea Against Karnataka HC Decision Restricting Admission to Private Schools’ (Livelaw, 19 August 2019) <<https://www.livelaw.in/top-stories/rte-sc-issues-notice-on-plea-against-karnataka-hc-decision-restricting-admission-to-private-schools-147292>> accessed 9 January 2020.

⁴¹ 137 S. Ct. 988 (2017).

⁴² Archana Mehendale, Rahul Mukhopadhyay, Annie Namala, ‘Right to Education and Inclusion in Private Unaided Schools: An Exploratory Study in Bengaluru and Delhi’ (2015) 50(7) EPW <<https://www.epw.in/journal/2015/7/special-articles/right-education-and-inclusion-private-unaided-schools.html>> accessed 17 October 2019.

⁴³ Section 18, RTE Act.

⁴⁴ Section 19, RTE Act.

⁴⁵ Section 19, RTE Act.

⁴⁶ Section 16, RPWD Act.

with disabilities” in the ways specified. It does not bring any sanctions with it unlike the RTE Act, where the non-implementation of norms and standards lead to derecognition.⁴⁷

As a result, the meaningful implementation of inclusive education in private unaided schools and specified schools is unlikely unless the appropriate government takes stringent actions. For instance, the Delhi Government recently released an order under Section 16 of the RPWD Act for implementing inclusive education in private unaided recognised schools of Delhi in line with the provisions of the Act.⁴⁸ The order also highlights the fact that the non-implementation of inclusive education will attract a penalty under Section 89 of the RPWD Act, which imposes penalties for contravention of the provision of the Act as well as under the Delhi School Education Act and Rules, 1973. Further, Uttar Pradesh⁴⁹ and Sikkim⁵⁰ have a provision under their state RPWD Rules that educational institutions may not be granted recognition unless they comply with Section 16 of the Act. However, other states do not seem to be taking similar actions to fulfill the mandate of inclusive education. In the absence of specific obligations for implementing inclusive education under the RTE Act, it is unlikely that it will be implemented in private unaided and specific category schools.

1.2.3 Special schools

a. Lack of clarity in the regulation of special schools

Special schools find mention in the RPWD Act. While the RPWD Act does not define a special school, it alludes to it in one single provision, in the context of children with benchmark disabilities (equal to or greater than 40% disability). The RPWD Act permits children with benchmark disabilities to opt for education, either in a neighbourhood school or a special school, upto the age of 18 years. It is also

specified that this provision supersedes all other provisions in the RTE Act. This implies that if a child between the ages of 6-18 years has a benchmark disability, it is their right to access education either in a neighbourhood school or a special school of their choice. Therefore, by giving children and their families the choice to opt for education in a special school, the RPWD Act is tacitly recognising the special schools model in India. The RTE Act, the primary law for regulating primary education, is silent on the aspect of special schools. The definition of the term ‘school’ in the RTE Act does not include special schools within its ambit.⁵¹

Further, special schools for children with intellectual disabilities are regulated under the National Trust Act, 1999.⁵² As a result of this, administratively, special schools come under the aegis of the MSJE and not the MHRD. This increases complexities in two ways: (i) it reinforces the idea that special schools are in fact not “schools” and hence outside the purview of the primary ministry responsible for overseeing education; (ii) it reinforces the need for inter-ministerial coordination.

Prior to the coming into force of the RPWD Act in 2017, the earlier PWD Act, 1995 cast an obligation on relevant governments to promote the setting up of special schools for those in need of special education. However, it had also failed to define or provide any universal standardisation for the regulation of special schools in India. As a result, despite various schools in India identifying as ‘special schools’ and seeking to provide education to children with disabilities, several of whom are denied admission everywhere else, they are not recognised or regulated as a ‘school’. These schools tend to be set up as ‘societies’ or ‘trusts’, under the law and perform a range of activities besides imparting education to children with disabilities.

⁴⁷ Section 19, RTE Act.

⁴⁸ “Implementing Inclusive Education in Private Unaided Recognized School of Delhi in the line of the Provisions under the Right of Persons with Disabilities Act, 2016”, Order dated 28 August 2019, Directorate of Education, Government of NCT of Delhi <http://www.edudel.nic.in/upload/upload_2019_20/10839_43_dt_11092019.PDF> accessed 9 January 2020.

⁴⁹ Rule 6, Uttar Pradesh Persons with Disabilities Rules, 2017.

⁵⁰ Rule 6, Sikkim Rights of Persons with Disabilities Rules, 2017.

⁵¹ Section 2(n), RTE Act.

⁵² Section 12.

b. Reconciling the notion of inclusive education with that of special schools

The RPWD Act casts an obligation on relevant governments to endeavour that all educational institutions funded or recognised by them provide inclusive education to children with disabilities.⁵³ In light of this, it is unclear how the special schools model may be reconciled with that of inclusive education.

This lack of clarity with the legal regime for special schools was demonstrated in the ongoing matter before the Supreme Court in which Vidhi had intervened.⁵⁴ In 2017, in relation to a matter of non-appointment of special educators in the State of Uttar Pradesh, the Supreme Court had stated that,

“We are of the prima facie view that the children with special needs have to be imparted education not only by special teachers but there has to be special schools for them.” The Court further stated that, “It is impossible to think that the children who are disabled or suffer from any kind of disability or who are mentally challenged can be included in the mainstream schools for getting an education. When we say disability, we do not mean ‘disability’ as has been defined in the Rights of persons with Disabilities Act, 2016. The Rights of Persons with Disabilities Act, 2016 includes certain physical disabilities which may not be a warrant for getting admission in special schools. The students who suffer from blindness, deafness and autism or such types of disorder may be required to have separate schools with distinctly trained teachers.”

At a time when domestic and international legal frameworks aim towards attaining inclusive education, the Supreme Court took a profoundly regressive view about the capabilities of persons with disabilities. Contrary to the view espoused by the Supreme Court, the RPWD Act refers to special schools only once, giving children with benchmark disabilities a choice to study in a special school. It is

evident that the RPWD Act entrusts the government with the obligation to create and maintain the very type of ‘inclusive education system’ which the court found impossible to even envision.⁵⁵ However, the Court later departed from this approach and directed the state of Uttar Pradesh to explain how it plans on operationalising the provisions on inclusive education set out under RPWD Act.⁵⁶

With respect to the monitoring and regulations of special schools, we found through our field visits that the current monitoring systems for special schools include norms around admission criteria, pupil-teacher ratio, and use of government funding. Special schools are required to admit students with benchmark disabilities or particular IQ levels, maintain a 1:8 teacher pupil ratio of children with intellectual disabilities, and provide timely reports about uses of MSJE grants. However, the quality of education at special schools is not regulated or monitored. As per the current institutional arrangements, the quality of special educators is maintained by the Rehabilitation Council of India (RCI), which provides licenses to all special educators, and have to be updated every five years. There are only few standards around fees for private providers, curriculum, pedagogical practices, or infrastructure. For example, a special educator at a public special school for children with intellectual disabilities in an urban centre in Maharashtra with 18 students did not have access to any modified curriculum or assessment for her students and the school had to report only student attendance to the MSJE.

1.2.4 Home based education

The term “home based education” has not been defined in either the RTE Act or the RPWD Act. The RTE Act mentions the term in the context of giving children with “multiple disabilities” and “severe disability” (terms now replaced by the RPWD Act) the right to opt for home based education.

⁵³ Section 16.

⁵⁴ Rajneesh Kumar Pandey & Ors. v. Union of India, WP(C) 132/2016 Supreme Court

⁵⁵ Madhavi Singh and Rahul Bajaj, ‘It’s Wrong to Say Children With Disabilities Can Only Be Educated in Special Schools’ (The Wire, 11 January 2018)

<<https://thewire.in/law/children-with-disabilities-special-schools-supreme-court>> accessed 13 April 2020.

⁵⁶ Prabhati Nayak Mishra, ‘SC Forms Advocates’ Panel To Inspect Special Schools In UP’ (Live Law, 4 December 2017)

<<https://www.livelaw.in/sc-forms-advocates-panel-inspect-special-schools-read-affidavit-order/>>

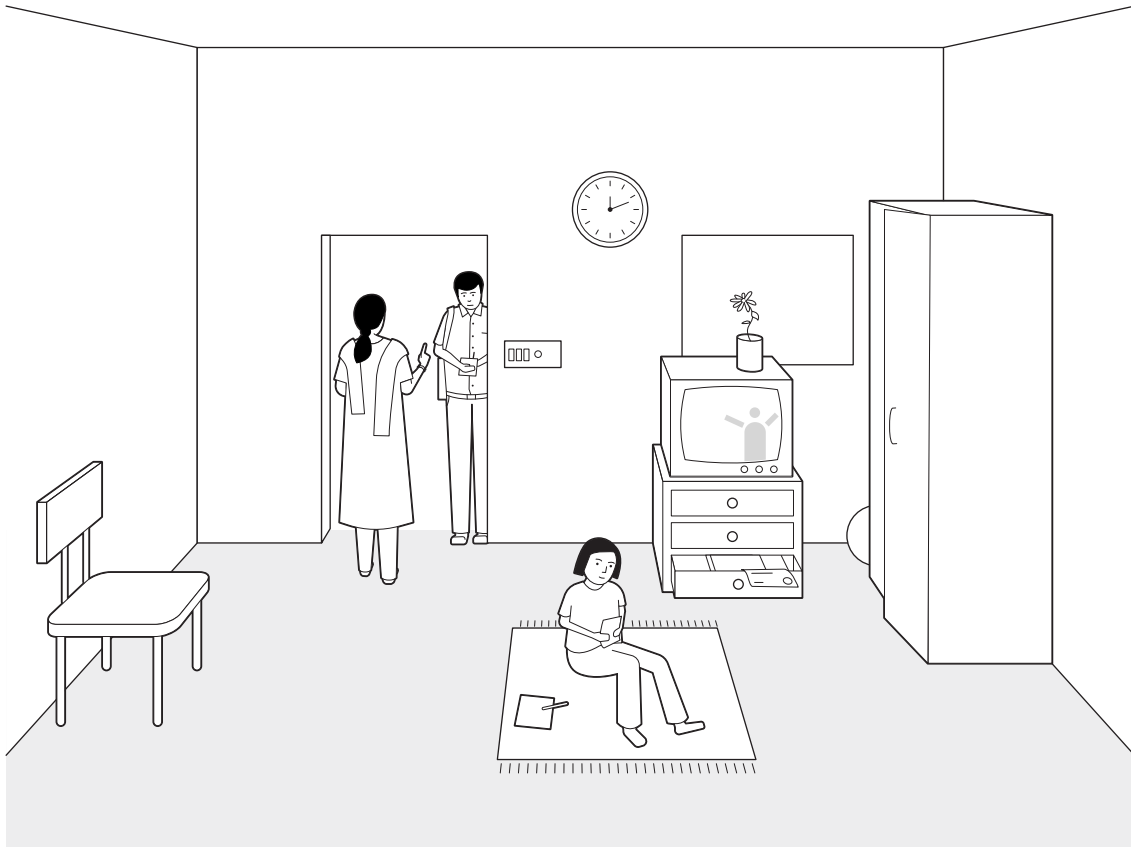

However, it doesn't define or explain what this implies.⁵⁷ It has been interpreted by some that home based education serves as a means for "special training" of children with high support needs at home. Such special training is to happen through regular teachers or teachers specifically appointed for the purpose with the end goal of their being mainstreamed into general schools along with their peers in the age appropriate class.⁵⁸

However, the lack of clarity around the model of home based education persists. With the coming into force of the RPWD Act, the terms "multiple disabilities" and "severe disability" have been replaced with that of "high support needs". This new terminology has not been incorporated into the RTE Act, which further leads to inconsistencies in the understanding and implementation of the legal framework related to children with disabilities

across both statutes. Further, the term has not been acknowledged or recognised in the RPWD Act, which focuses on inclusive education instead. The only exception that the RPWD Act makes is for children with benchmark disabilities, who may opt for education in special schools.⁵⁹

The practice of home based education was first introduced by the SSA in 2006 as a 'pathway to inclusion'. The SSA sought to explain the concept of home based education in the following way: *"Generally home-based education is defined as the education of children with severe intellectual/physical disabilities, who can be educated in the combination of home-based and alternate educational settings to enable them to achieve independent living skills. Home-based education aims at school preparedness and preparation for life. Alternate educational settings provide opportunities for learning social skills, vocational*

⁵⁷ Proviso to Section 3(3), RTE Act.

⁵⁸ Anita Julka, "An Exploratory Study of Home Based Education Practices: A Draft Report", NCERT <http://www.ncert.nic.in/departments/nie/degsn/pdf_files/Eshbep_degsn.pdf> accessed 6 January 2019.

⁵⁹ Section 31, RPWD Act.

skills and implementation of life skills”.⁶⁰ In 2011, the SSA had further stated that school preparedness of CWSN must be ensured by providing ‘special training’ as envisaged in the RTE Act. It clarified that this training may be residential, non-residential or even home based, as per their specific requirements. The existing non-formal and alternate schooling (including home based education) options for children with disabilities can be recast as ‘special training’ in the context of the RTE Act.⁶¹

Under the current SSA structure, CWSN resource persons are responsible for home based education in their blocks. The resource persons perform a variety of services through home based education, ranging from physiotherapy to activities of daily living to the creation of individualised education plans. These tasks may not always correspond to the specific disability that the resource person was trained in. In most states, home based education was provided through volunteers before it became the responsibility of the resource persons. According to several stakeholders, this move has led to a further neglect in home based education. Resource persons have multiple responsibilities, are under-resourced, and cover more schools than they can manage. This prevents regular follow up that children undertaking home based education require. To overcome this, regular trained teachers also provide home based education.

As of 2015-16, official data produced by the MHRD stated that of the 27.79 lakh CWSN identified, 1.16 lakh CWSN are being provided home based education.⁶² However, across regions, there was a lack of clarity regarding the enrolment status of children in home based education. In some cases, we were informed that these children were enrolled in the nearest government school and received SSA entitlements and benefits through that. In other regions, they were enlisted as out-of-school children. Sometimes, we found both approaches in

the same state. This lack of clarity implies that there are perhaps no reliable figures of how many children with disabilities undertake home based education. It is no surprise then that several officials and special educators complained about the quality of services that are provided to these children, “children with intellectual disability, visual impairment are doing home based and the resource person is visiting them once a week, otherwise the child is doing nothing.” In some cases, there were cultural barriers to regular home visits by the resource persons. Male resource persons in rural Haryana stated that since their visits were during working hours, they would often visit households when only female members were at home and male members were at work. They found that this would lead to rumours in the village. Male resource persons were thus unable to conduct regular visits as they feared for their safety. Sometimes parents have to take the child to the school and schools are situated far away. In cities, they claim that you can find schools within 1 km of your neighbourhood but that is not the case in rural areas” (rural Meghalaya). For some officials, children with severe and multiple disabilities require home based education. However, they believed that it should not become the norm, but an option reserved for exceptional circumstances.

1.2.5 School models and Parental choice

The RTE Act casts a duty on every parent to admit their child or ward to a neighbourhood school for elementary education.⁶³ However, it allows parents of children with “multiple disabilities” or “severe disabilities” to opt for home based education.⁶⁴ The RPWD Act, which doesn’t recognise home based education models, allows parents of children with benchmark disabilities to opt for education in a special school.⁶⁵ In practice, the implementation of these provisions, be it finding and enrolling a child with disabilities in a nearby school that is suitable to their requirements, or exercising the right to choose

⁶⁰ Anita Julka, “An Exploratory Study of Home Based Education Practices: A Draft Report”, NCERT <http://www.ncert.nic.in/departments/nie/degsn/pdf_files/Eshbep_degsn.pdf>, accessed 6 January 2019.

⁶¹ *Ibid.*

⁶² MHRD, Annual Report 2015-16 <https://mhrd.gov.in/sites/upload_files/mhrd/files/document-reports/AR_2015-16%20ENGLISH.pdf> accessed on 9 January 2020.

⁶³ Section 9, RTE Act.

⁶⁴ Proviso to Section 3(3), RTE Act.

⁶⁵ Section 31, RPWD Act.

from different school models, is complicated. As a mother of a child with hearing impairment told us in rural Madhya Pradesh, *“I hope he finishes school but if he doesn’t he will work with us on the fields. We never taught him but he learned how to work on the field by watching us.”*

For one, while the choice to opt for home based education vests with the child with high support needs, the choice is usually made by the school administration, teachers or doctors for the parents. Further, based on interviews, other factors that influence the school choice for parents include tensions between financial constraints, child’s physical and emotional safety, and the child’s economic future.

A constant fear in the minds of many parents is how the child would survive as an adult, *“I am always tense, I keep thinking, after me, what? If something happens to me, what? What if something happens to my husband, what will happen in the future? This is a big issue for us,”* expressed a mother of a child with intellectual and physical disabilities in urban Maharashtra. Parents in urban areas seek and demand schools that provide individualised care for their children based on the unique needs and requirements of the child’s disability. Many parents and special educators demand vocational training for children with disabilities in schools to ensure the child has some employable skills. In rural Madhya Pradesh and Haryana, parents were less likely to express fears about the child’s economic prospects.

The desire for individualised care and services for many urban parents also stems from fears about the child’s safety in a mixed environment. For parents, mixed environments are not just environments where there are children with and without disabilities but also contexts with children with different kinds of disabilities. Parents hope to select schools that provide holistic facilities around schooling, medical and therapeutic services for cost-effective investment of time and money in accessing these services. More often in urban areas, it was the

mother who was tasked with accompanying the child to school, to the hospital, and to therapy. Mothers in urban regions would often stay with the child during school hours.

Parents would vocalise their preference for schools close to their place of residence. For some, the issue was the cost of transportation, for others, the issue was a lack of means of transportation. For some, their child’s disability made it difficult for them to travel independently or travel at all. Thus, school choice is further complicated not just by rural-urban and socio-economic divisions, but by disability type and the severity of the child’s disability. Additionally, parents of children with multiple disabilities often find themselves in a difficult position. As one parent of a child with hearing, physical, and intellectual disabilities told us, the special school for hearing impairment stated that they would not be able to support his physical needs or guarantee his safety. The individual specialisation of most special schools proves to be a challenge for children with multiple disabilities or multiple needs. An important consideration in relation to access to schools is that schools will respect parental choice. Several parents who sent their children to special schools stated that they initially sent their child to a neighbourhood school. However, these schools often had the child be moved to a special school once they discovered the child’s disability. Teachers stated that they were unable to cope with the child’s needs or that they were unable to prevent bullying by other children. For some parents, it was the doctor who recommended the child be moved to a special school.

A key challenge, especially for parents experiencing poverty, is the lack of awareness about the choices available for their child’s unique needs. Based on interviews and observations, we found that parents with lower levels of education are less likely to be aware of government entitlements and how to set up and access banking facilities to receive the entitlements. There is also the stigma surrounding disability⁶⁶ which may lead parents to not invest

⁶⁶ S Edwardraj and others, ‘Perceptions about Intellectual Disability: A Qualitative Study from Vellore, South India’ (2010) 54 Journal of Intellectual Disability Research 736; Anita Ghai, ‘Disabled Women: An Excluded Agenda of Indian Feminism’ (2002) 17 Hypatia 49; Misa Kayama, Christopher Johnstone and Sandhya Limaye, ‘Adjusting the “Self” in Social Interaction: Disability and Stigmatization in India’ (2018) Children and Youth Services Review.

time, effort, and financial resources on the education of children with disabilities. Several stakeholders in the study reported instances of parental neglect and discrimination against children with disabilities, particularly girls with disabilities.

Parental training and community mobilisation are part of the existing mandate of the SSA and the new Samagra Shiksha Abhiyan. However, as we found in Madhya Pradesh, these programs are usually organised at the district level and have a budget for 100 parents to attend in a district with at least 2000 children with disabilities currently enrolled in school.⁶⁷ Thus, targeting these campaigns at the cluster or block level and funding them appropriately is likely to have a greater impact on the enrolment of children with disabilities.

⁶⁷ U-DISE, 2017

II

Entering the education system

2.1 Identification

The identification of children with disabilities is the starting point for ensuring their access to and enrolment in a neighbourhood school. There is an alarming shortage of data on the number of children with disability in India. This makes it harder to determine whether disabled children of school-going age are in school or not.

The RTE Act casts a duty on the local authority to maintain records of children up to the age of fourteen years residing within its jurisdiction.⁶⁸ However, there isn't an equivalent obligation for maintaining data in the context of children with disabilities. The central RTE rules mandate that the local authority be responsible for maintenance of records related to children of school going age. It specifies that the local authority maintain a database of all children from birth upto the age of 14 within its jurisdiction, through a household survey. This database is to include details such as whether the child belongs to the weaker sections, disadvantaged sections, or whether the child requires special facilities or residential facilities on account of disability.⁶⁹

At the state level, rules formulated by some state governments for the implementation of the RTE Act have similar provisions. State rules of Madhya Pradesh and Bihar, for example, mandate the local authority to maintain data of children who are "disadvantaged" or from the "weaker sections" of school going age in a neighbourhood.⁷⁰ However, this lumps children with disabilities along with

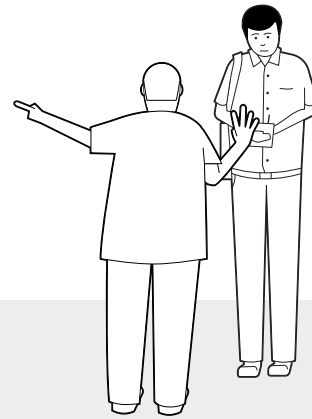

children from economically weaker sections, and consequently overlooks their specific needs and challenges.

The SSA, which states that it seeks to provide inclusive education to all CWSN in "general schools", highlights the need for their identification and mapping. It states that concerted efforts must be made to detect CWSN at an early age through public health centres, ICDS, ECCE centres and other school readiness programmes. It also highlights the need for training of the surveyors, enumerators and other government functionaries at different levels.

However, on the ground, the identification process varies drastically in each state. Some districts conduct household surveys, some do a cursory visit to the villages, and some rely on teachers. Others also visit anganwadis for the school readiness program. In rural Haryana, for example, CWSN

⁶⁸ Section 9, RTE Act.

⁶⁹ Rule 10(4) (g)(h)(i), Central RTE Rules.

⁷⁰ Madhya Pradesh: Madhya Pradesh RTE Rules, 2011 <<http://righttoeducation.in/sites/default/files/RTE%20Rules%20of%20Madhya%20Pradesh%20%5BHindi%5D.pdf>>; Bihar: Bihar RTE Rules, 2011 <[https://mhrd.gov.in/sites/upload_files/mhrd/files/upload_document/bihar-rte-rules_english%20\(1\).pdf](https://mhrd.gov.in/sites/upload_files/mhrd/files/upload_document/bihar-rte-rules_english%20(1).pdf)>.

resource persons visit villages. Three resource persons are tasked with covering 84 villages in a month. Given this mammoth ratio, resource persons usually get information from local informants in public areas of the village. On the other hand, in rural Assam, resource persons conduct school visits and household visits to identify children with disabilities. In rural Madhya Pradesh, resource persons rely on teachers to relay information about children with disabilities and only visit schools that do not furnish numbers of children with disabilities. A government official in urban Maharashtra stated that relying on teachers led to an overestimation of children with learning disabilities.

The absence of a thorough methodology for identification is a major challenge. A resource person in rural Assam stated that they had no doubt that their identification process leaves some children behind. Additionally, resource persons are trained in a singular disability type (such as visual impairment or cerebral palsy). Judgments made by a resource person trained in visual impairments about autism thus become suspect. Several resource persons were not confident of their ability to make these judgments, “we’re not doctors,” we were told. The lack of training holds even more for teachers. Given the shortage of resource persons and their inability to cover all the schools in their block, they often get their information about disabled children from teachers. There are likely to be cases of both over and under-identification of disabilities, particularly intellectual and learning disabilities. For example, in rural Meghalaya, a government official highlighted that teachers often mislabel first-generation learning differences in home and school language as one having a learning disability.

2.2 Certification

The disability certificate plays an important role when it comes to the education of children with disabilities. Though one does not need a disability certificate for admission in government schools, it is a necessary requirement to be eligible for free education in a private unaided school under the 25% reservation quota. Further, to get certain benefits under the SSA and various schemes of the MSJE, which will be discussed in the next section in detail, children with disabilities need a disability certificate. Note that some states like the National Capital Territory (NCT) of Delhi have tried to simplify this process on grounds of equity by issuing guidelines to the effect that lack of such certificates cannot be a ground to deny admission to children. However, most states have not taken this step.⁷¹

The RPWD Act provides that any person with disabilities specified in the Schedule may apply for a disability certificate.⁷² As per the Act read with the RPWD Rules, persons with specified disabilities (disabilities specified in the Schedule to the RPWD Act) may apply for a certificate of disability. The application can be made to a medical authority, or any other notified competent authority in the district of residence, or the concerned medical authority in a government hospital where they may have undergone treatment in connection with their disability.⁷³ The certifying authority, on verifying the information and assessing the extent of disability on the basis of the Guidelines issued by the Central Government,⁷⁴ can issue a disability certificate. It can either be a permanent certificate or a temporary disability certificate with the period of validity where there is any chance of variation over time in the degree of disability.

However, for children below 5 years of age with intellectual disabilities, only a temporary certificate can be issued, which is to be renewed at the age of 5 years, 10 years and 18 years. For children with

⁷¹ 'Regarding instructions/guidelines for aspirants of the category of Children with Disabilities as defined in the Rights of Persons with Disabilities Act, 2016 to apply online against the vacant seats at the entry level classes (Nursery, KG & Class-I) for the session 2018-19, Circular dated 26 July 2018, Directorate of Education, Government of NCT of Delhi <http://www.edudel.nic.in/upload/upload_2017_18/27068_73_dt_26072018.pdf> accessed 9 January 2020.

⁷² Section 58, RPWD Act.

⁷³ Section 58, RPWD Act; Rule 17, RPWD Rules.

⁷⁴ Rule 18, RPWD Rules.

specific learning disabilities (SLD), certification can be done once they are 8 years old, following which there will be repeat certification at the age of 14 years and 18 years. The certificate issued at 18 years, in both the cases, will be valid life-long.

The certifying authorities may certify that a child has benchmark disability if they have not less than forty percent of a specified disability where specified disability has not been defined in measurable terms. Benchmark disabilities also include such specified disabilities which have been defined in measurable terms.⁷⁵ Persons with benchmark disabilities are given additional benefits under both the SSA and the RPWD Act. Further, children with benchmark disabilities, who need high support⁷⁶ may apply to the authority notified by the State Government or the Union Territory Administration to provide them with high support.⁷⁷ The application is then referred to the Assessment Board, constituted at the district or division level according to the number of persons with benchmark disabilities. Only persons with benchmark disabilities who have a permanent certificate can apply for high support. The Board assesses the case and sends a report to the Authority certifying the need of high support and its nature. The Authority then takes steps to provide required support as per the appropriate government's schemes in this regard.⁷⁸

2.2.1 Role of schools and teachers in facilitating disability certificate

a. Assessment of disability

The RPWD Act provides that educational institutions shall detect specific learning disabilities in children at the earliest and take suitable pedagogical and other measures to overcome

them.⁷⁹ The 'Guidelines for the purpose of assessing the extent of specified disability'⁸⁰ specify a detailed procedure as well as the composition of the medical authority for assessing each kind of disability including specific learning disabilities. While different specialists, like an ENT specialist for assessing speech and language disability, are required to be a part of the medical authority for each kind of disability, teachers and special educators have been assigned important roles in the screening and assessment of SLDs.

As per Guidelines, the teachers of public and private schools shall screen children in Class III or at 8 years of age, whichever is earlier. After applying the screening test, if an anomaly is detected they should then bring it to the notice of the screening committee of the school headed by the principal. However, these guidelines do not provide the details of the screen test and the manner in which it is to be conducted. The teachers are also required to interview parents to assess their involvement and motivation regarding their child's education. If parents are motivated and the screening questionnaire suggests an SLD, then the child shall be referred to a paediatrician for SLD assessment by the principal of the school with the recommendations of the screening committee. The detailed diagnosis is then to be carried out by the medical authority, which shall comprise an occupational therapist or special educator or teacher trained for assessment of SLD in addition to the Medical Superintendent, a paediatrician and a clinical or rehabilitation psychologist.

⁷⁵ Section 2(r), RPWD Act.

⁷⁶ Section 2(l): "high support" means an intensive support, physical, psychological and otherwise, which may be required by a person with benchmark disability for daily activities, to take independent and informed decision to access facilities and participating in all areas of life including education, employment, family and community life and treatment and therapy.

⁷⁷ Section 38, RPWD Act.

⁷⁸ Rule 14A, RPWD Rules.

⁷⁹ Section 16, RPWD Act.

⁸⁰ Guidelines for the purpose of assessing the extent of specified disability in a person included under the Rights of Persons with Disabilities Act, 2016, MSJE
<https://upload.indiacode.nic.in/showfile?actid=AC_CEN_25_54_00002_201649_1517807328299&type=notification&filename=Guidelines%20notification_04.01.2018.pdf> accessed 11 April 2020.

b. Issuance of certificate

To simplify the procedure for the issuance of disability certificates given under the Persons with Disabilities (Equal Opportunities, Protection of Rights and Full Participation) Rules, 1996, DEPWD issued specific guidelines for students with disabilities.⁸¹ As per the Guidelines, it is the responsibility of the principal/headmaster to arrange for the issuance of certificates. On a written request of school authorities, the District Medical Board should visit the school for evaluation of the disability of the student and issue a certificate as per the notified guidelines. In case the Medical Board is of the view that the evaluation of disability of a particular student can be done only after carrying out certain tests with the equipment available in the district hospital, the student should be brought to the hospital. The school authority shall make arrangements for the visit. The expenditure will be borne by the Education Department of the State Government / UT Administration and no fee should be charged from the disabled students for the issue of disability certificate. While these Guidelines are still available on the Department's website, with the coming into force of the RPWD Act, their current status is unclear.

Disability certificates are important as they provide parents access to aids, appliances, and scholarships from the SSA and MSJE. Certificates are also important for admissions into special schools. Based on the disability type, special schools have a particular percentage cut-off for admission. For example, a private special school in rural Haryana only admitted students who had greater than 70% hearing impairment as per their certificate. A private special school in urban Maharashtra for children with intellectual and cognitive disabilities stated similar criteria with regard to IQ level (IQ of 70 or less). A government special educator in urban Maharashtra suggested that the disability certificate for children with intellectual disabilities includes a recommendation of whether a child should be enrolled in a special school. This points to the confusion around the content of and the outcomes associated with the certification process.

Key resources and stakeholders for parents in the certification process are doctors, resource persons, and special educators. In interviews across states, medical camps organised via the SSA are the primary means for parents to obtain disability certificates. However, some resource persons complained that misdiagnosis was common at these camps: "there are a large number of children, and doctors are diagnosing these children in a hurry." (Meghalaya, rural) This particular special educator found that parents are intimidated by the doctors and often do not share all the details about their child. According to them, special educators must be present with the parents to assist this process.

Apart from medical camps, which are organised annually or biennially, disability certificates are usually made once a week at District Disability Rehabilitation Centres (DDRCs). Parents and special educators across states complained of lengthy and often complicated procedures at the DDRC: parents often cannot afford to travel to the district centre, existing procedures for making disability certificates are lengthy, and require multiple visits. Several CWSN resource persons, particularly in Madhya Pradesh, mentioned how they assist parents with the certification process at the DDRC by paying for the form themselves, getting copies of the required documents, and transporting the parents and the child to and from the DDRC.

DDRCs often do not have specialists required to correctly diagnose and certify particular kinds of disabilities. There were several complaints about inadequate IQ assessments, lack of specialised doctors for the twenty-one disability types, and overall issues with the diagnosis obtained. For example, in rural Meghalaya, a child was initially diagnosed as hearing impaired, only to be later diagnosed with an intellectual disability.

Across regions, various stakeholders recommended that the process of making disability certificates be shifted to the block level to ensure that parents have easy access to these centres. They also recommended that DDRCs and medical camps should have inclusive facilities that cater to the

⁸¹ Guidelines for Issue of Disability Certificate, DEPWD, MSJE.

<<http://disabilityaffairs.gov.in/content/page/guidelines.php#dc>> accessed 9 January 2020.

twenty-one disability types as much as possible to prevent parents from having to run around to get a disability certificate made for their child.

2.3 Benefits

There are different kinds of facilities that are to be provided to children with disabilities for the meaningful implementation of inclusive education as per the mandate of the RPWD Act. Although the RTE Act is mostly silent on this, the corresponding Central Rules framed under the RTE Act have certain provisions in this regard. Further, the SSA provides for an expenditure of up to Rs. 3000 per disabled child that could be incurred in a financial year to meet the special learning needs of the children.⁸² It also stipulates that assessment of each identified child with a disability needs to be carried out to ascertain the extent and type of disability, the developmental level of the child, the nature of support services required, assistive devices required by the child and the most appropriate form of special training to be given to the child. The MSJE has also launched certain schemes in this regard like the Scheme of Assistance to Disabled Persons for Purchase/Fitting of Aids and Appliances ('ADIP Scheme'), which works in convergence with SSA for the delivery of benefits to children with disabilities. The kinds of benefits available to children with disabilities can be categorised under the following heads:

2.3.1 Transport facilities

The RPWD Act provides that educational institutes, in order to facilitate inclusive education, shall provide transport facilities to children with disabilities who have high support needs and also

to their attendants.⁸³ Although the RTE Act does not specify anything in this regard, the Central RTE Rules require the appropriate government or the local authority to make appropriate and safe transportation arrangements for children with disabilities to enable them to attend school and complete elementary education.⁸⁴ To implement this, the SSA provides for transport and escort allowance. However, it adds that the State RTE Rules must notify the area/limits of neighbourhood in which transport/escorts facility is to be provided to the specified categories of children. So far, 19 states⁸⁵ have a provision for transport facilities to children with disabilities in their State RTE Rules. Although such provisions exist, the on-ground reality is completely different. The table below⁸⁶ shows the shortfall in providing transport allowance in Assam, Kerala and Tamil Nadu. All three states have a provision for transport allowance in their RTE Rules.

2.3.2 Aids and appliances

The RPWD Act casts obligations on the appropriate governments and local authorities to take specific measures to facilitate inclusive education, which include providing books, other learning materials and appropriate assistive devices to students with benchmark disabilities free of cost, up to the age of eighteen years.⁸⁷ While the RTE Act talks about learning material and equipment for children in general, it does not have any specific provisions for children with disabilities. The Central RTE Rules, however, prescribe that a child with a disability shall be entitled to free special learning and support material. The Rules also provide that the responsibility of providing free entitlements to children with disabilities admitted in private unaided and specified category schools under Section 12(1) (c) of the RTE Act will be that of the respective

⁸² The ceiling on expenditure per disabled child applies at the district level.

⁸³ Section 16, RPWD Act.

⁸⁴ Rule 6, Central RTE Rules, 2010.

⁸⁵ Tamil Nadu, Andhra Pradesh, Arunachal Pradesh, Assam, Bihar, Chhattisgarh, Haryana, Himachal Pradesh, Karnataka, Kerala, Madhya Pradesh, Maharashtra, Meghalaya, Mizoram, Orissa, Punjab, Rajasthan, Sikkim, Tripura.

⁸⁶ Report of the Comptroller and Auditor General of India on Implementation of Right of Children to Free and Compulsory Education Act, 2009 for the year ended March 2016 <https://cag.gov.in/sites/default/files/audit_report_files/Report_No.23_of_2017_%E2%80%93_Combpliance_audit_Union_Government_Implementation_of_Right_of_Children_to_Free_and_Compulsory_Education_Act%2C_2009.pdf> accessed 9 January 2020.

⁸⁷ Section 17, RPWD Act.

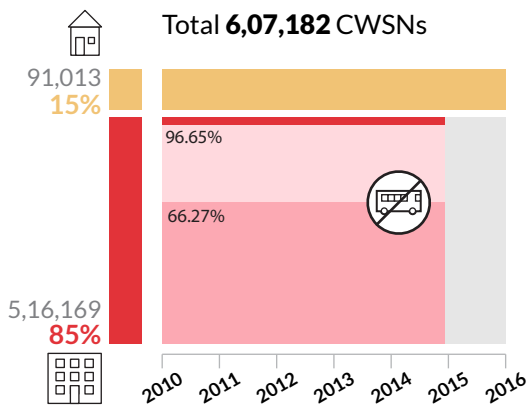

Assam

Out of 6,07,182 CWSNs identified, 5,16,169 (85 per cent) were enrolled in schools and the balance (15 per cent) were provided Home Based Education. The shortfall in providing Transport Allowance (TA) to CWSNs enrolled ranged from 66.27 per cent to 96.65 percent during 2010-15. No TA was provided during 2015-16 due to non-receipt of funds from Gol.

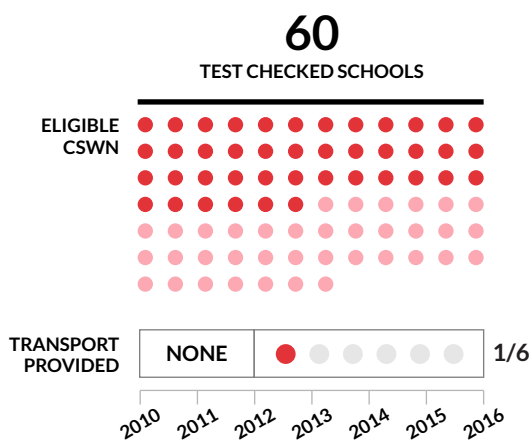

Kerala

In 60 test checked schools in Thrissur and Idukki Districts, 42 to 79 CWSNs were eligible for free and safe transportation facility during the period 2010-11 to 2015-16. However, no free and appropriate transportation facility was provided to any of those students during 2010-11 and 2011-12. Transportation facility was given only for 1 to 6 students during the period 2012-13 to 2015-16.

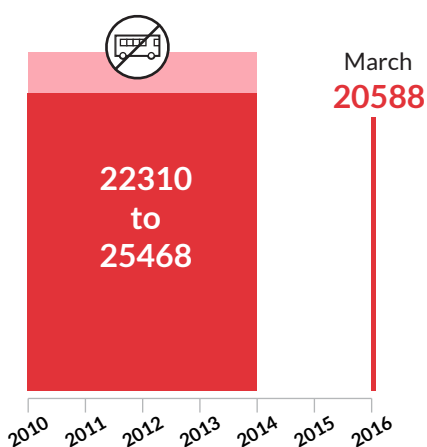

Tamil Nadu

22,310 to 25,468 CWSNs, identified during 2010-14, were not provided transportation as funds were not allotted for this component by SSA, though funds were allotted under Inclusive Education for Disabled (IED). As of March 2016, 20,588 CWSNs were not provided with transport arrangements.

Source: Report of the Comptroller and Auditor General of India on Implementation of the RTE Act, 2009 (March 2016).

schools.⁸⁸ While 17 states⁸⁹ have a provision for free special learning, support material, and equipment in their State RTE Rules, 2 states⁹⁰ provide only for free special learning and support material. Other states do not have any provision in this regard.

With the objective of providing aids and assistive devices to persons with disabilities to improve their independent functioning, the ADIP Scheme was launched by the MSJE in 1981, and later revised in 2014. The ADIP Scheme has been running in convergence with the SSA since 2004 as the ADIP-SSA programme to distribute aids and assistive devices to children with disabilities below fourteen years of age. The Artificial Limbs Manufacturing Corporation of India (ALIMCO), a Government of India undertaking under MSJE, is the nodal implementing agency for both the programmes.⁹¹ As per the agreement with the MHRD, ALIMCO is reimbursed 40% of the expenditure of the ADIP-SSA Programme by the State Government Authorities and 60% of the expenditure through grants under ADIP Scheme.⁹² ALIMCO organises ADIP-SSA camps to distribute aids and appliances to children with disabilities on communication from the state/local authorities or CSOs.⁹³ However, the Standing Committee on Social Justice and Empowerment in its sixty-first report observed that no ADIP-SSA camp activity happened in the States of Arunachal Pradesh, Mizoram, Sikkim, Nagaland, Jharkhand, Himachal Pradesh and UTs of Lakshadweep and Puducherry during 2015-16 to 2017-18. Meghalaya held only 5 ADIP-SSA camps covering 857

beneficiaries in 2016-17. The Committee also found that only 2,34,113 children with disabilities were covered under ADIP-SSA camps all over India from the year 2015 to 2018.⁹⁴

Initially, the eligibility criteria to avail benefits under ADIP Scheme was to have certification specifying at least 40 percent disability.⁹⁵ It was observed by the DEPWD that many children with disabilities did not possess disability certificates and therefore were deprived of benefits under this scheme.

As a result, 'disability certification' norms were reconsidered for children with disabilities under ADIP-SSA to have 100% coverage, and guidelines were issued in this regard by the MSJE in 2015.⁹⁶ These guidelines imposed the responsibility for issue of a 'Joint Disability Certificate' on the principal/headmaster of the school, government doctor of the Primary Health Centre or Community Health Centre, local SSA Authority and representatives of ALIMCO. These guidelines also provided that in case of children with less than 40% disability, aids and assistive devices could still be issued based on the Joint Disability Certificate. However, not many people seem to be aware of this provision and the issuance of disability certificate is usually linked to the 40% disability criteria. Further, the cost coverage ceiling for children with disabilities under ADIP-SSA was also revised to Rs. 12,000. In addition to the ADIP-SSA Programme, the SSA Framework also provides that if aids and appliances cannot be obtained through convergence, then SSA funds could be used for this purpose too.⁹⁷

⁸⁸ Rule 9, Central RTE Rules.

⁸⁹ Uttar Pradesh, Andhra Pradesh, Arunachal Pradesh, Assam, Bihar, Chhattisgarh, Haryana, Himachal Pradesh, Jharkhand, Karnataka, Kerala, Maharashtra, Meghalaya, Mizoram, Orissa, Punjab, Sikkim.

⁹⁰ Tamil Nadu and Rajasthan.

⁹¹ Standing Committee on Social Justice and Empowerment, *Review of the Functioning of Artificial Limbs Manufacturing Corporation of India (ALIMCO)*, (LS 2017-2018, 61) <http://164.100.47.193/lssccommittee/Social%20Justice%20&%20Empowerment/16_Social_Justice_And_Empowerment_61.pdf> accessed 9 January 2020.

⁹² "National Sports Centres for Divyangs", Parliamentary Starred Question Number 382, Lok Sabha, answered on 8 January 2019, MSJE <<http://164.100.47.194/Loksabha/Questions/QResult15.aspx?qref=78130&lno=16>> accessed 9 January 2020

⁹³ Standing Committee on Social Justice and Empowerment, *Review of the Functioning of Artificial Limbs Manufacturing Corporation of India (ALIMCO)*, (LS 2017-2018, 61) <http://164.100.47.193/lssccommittee/Social%20Justice%20&%20Empowerment/16_Social_Justice_And_Empowerment_61.pdf> accessed 9 January 2020.

⁹⁴ *Ibid.*

⁹⁵ Scheme of Assistance to Disabled Persons for Purchase/Fitting Of Aids/Appliances (ADIP Scheme), MSJE <<http://disabilityaffairs.gov.in/upload/uploadfiles/files/sipda/adiprevised010414.pdf>> accessed 9 January 2020.

⁹⁶ Revised Scheme of Assistance to Disabled Persons for Purchase/Fitting Of Aids/Appliances (ADIP)- Guidelines for Issuance for Disability Certificates to Children with Special Needs (CWSN) for assistance under ADIP-SSA, MSJE <<http://disabilityaffairs.gov.in/upload/uploadfiles/files/CWSN-ADIPSSA-DA.pdf>> accessed 9 January 2020.

⁹⁷ Sarva Shiksha Abhiyan Framework for Implementation: Based on the RTE Act, MHRD <https://seshagun.gov.in/sites/default/files/2019-05/SSA-Frame-work_0.pdf> accessed 9 January 2020.

2.3.3 Financial Assistance

The RPWD Act casts an obligation on the appropriate government and local authorities to provide scholarships in appropriate cases to students with benchmark disability for facilitating inclusive education. There are also provisions in some states for providing financial assistance to children with disabilities. For instance, in Madhya Pradesh, the Social Justice and Disabled Welfare Department provides scholarships to disabled students, reader allowance to those with visual impairment and incentive amount to excellent students. Under this scholarship, students possessing a 40% disability certificate and enrolled in a government or any recognised educational institution are given Rs. 500 for ten months at the primary and middle level provided the annual income of their parents or guardian does not exceed Rs. 96,000.⁹⁸ However, the scholarship benefits are processed by the Department of School Education. In Haryana, the Department of Social Justice and Empowerment provides financial assistance of Rs. 1200 per month to non-school going disabled children below 18 years of age.⁹⁹ Only those children who have a domicile of Haryana, have intellectual disability with IQ <50 or minimum 70% disability, cerebral palsy, autism, multiple disability of 70% or more or orthopaedic disability of 100% are eligible under this scheme.¹⁰⁰ In Uttarakhand, the guardian(s) of children with disabilities between 0-18 years of age are given a monthly allowance of Rs. 700. The Uttaranchal High Court in *Kamal Gupta v. State of Uttarakhand and Ors. directed the State Government* that CWSN shall be paid a scholarship of Rs. 1,000/- per month. The above is reflective of the variations in financial assistance that exist across the states as there is no fixed minimum mandate for financial assistance under the law.

During our field visits, we observed that access to most MHRD and MSJE schemes related to aids, appliances, and scholarships for children with

benchmark disabilities are tied to the certification process. Across several states, it appeared that fittings for aids and appliances were done at medical camps, often by a third-party provider (ALIMCO in most cases). CWSN resource persons stated that it was part of their role to ensure that children with disabilities received these aids and entitlements. In some states, they even ensured delivery of entitlements from the MSJE. There were complaints about the quality of aids and appliances provided such as the following: “they are undersized or oversized and do not suit the needs of the child; they do not modify it according to the needs of the child” (rural, Meghalaya). In some places, these camps were not organised regularly and there were few options for replacements in case of broken aids. Overall, parents, special educators, and teachers listed several grievances with these government entitlements. The first was that the entitlements were not adequate to meet the child’s needs. In urban areas, the inadequacies were related to transport allowances. In rural areas, they were related to insufficient funds for treatments and therapies. Not only were the entitlements inadequate but they were often delayed or denied. Several parents, especially in rural areas, were not aware of how to receive their entitlements. The government has moved entirely to bank transfers of funds with the responsibility of creating bank accounts of parents vesting in the schools. However, parents often did not have information about the existence of these bank accounts, where the bank was, or how one could access these funds.

⁹⁸ Scholarship for Disabled Students, Signatory Allowance to Visually Handicapped and Incentive to Excellent Students, Social Justice and Disabled Welfare Department, Government of Madhya Pradesh <<http://socialjustice.mp.gov.in/hi-IN/Scholarship-for-disabled-students-reader-allowance>> accessed 9 January 2020.

⁹⁹ Financial Assistance to Non School Going Disabled Children (less than 18 Years) Scheme, Government of Haryana <<https://haryana.gov.in/scheme/financial-assistance-to-non-school-going-disabled-children-18-years/index.html>> accessed 9 January 2020.

¹⁰⁰ Financial Assistance to Non-school Going Disabled Children (< 18 Years), Eligibility Criteria, government of Haryana <<https://cdn.s3waas.gov.in/s36e7b33fdea3adc80ebd648fffb665bb8/uploads/2018/10/2018100414.pdf>> accessed 9 January 2020.

III

Aspiring to learning as a child with disability

3.1 Teachers

3.1.1 Qualification requirements

As per the RTE Act, any person who possesses minimum qualifications as laid down by the National Council of Teachers' Education ('NCTE') can be appointed as a teacher.¹⁰¹ The RTE Act also provides certain flexibility with respect to minimum qualifications. It initially allowed states to relax on minimum qualifications for up to five years if they did not have enough qualified teachers. It also allowed teachers who did not possess the minimum qualifications at the time of the commencement of the Act to acquire them within five years of the passage of the Act. However, the RTE Amendment Act, 2017 has extended this period till the year 2021.¹⁰² This shows that we still lack teachers possessing minimum qualifications laid down by the NCTE.

As a part of these minimum qualifications, the NCTE mandates pre-service training for teachers either through a diploma or a bachelor's degree in education. However, the NCTE has not made a bachelor's degree in special education mandatory; it is optional.¹⁰³ When it comes to the curricula of these courses, they are not designed also from the perspective of children with disabilities, inclusive education is merely taught as a paper in these courses.¹⁰⁴ As a result, teachers are not fully trained to teach children with disabilities even after attending these courses.

3.1.2 On going teacher training and upskilling

The RTE Act provides that the Central Government shall develop and enforce standards for training of teachers,¹⁰⁵ and the appropriate government¹⁰⁶ and the local authority¹⁰⁷ shall provide training facilities for teachers. However, both the RTE Act and the Rules framed by the Central Government are silent on the aspect of training to cater to the needs of children with disabilities. The RTE rules in states like Andhra Pradesh and Kerala, on the other hand, prescribe that teachers shall be trained in teaching methods for CWSN.¹⁰⁸ The SSA Framework also provides that intensive teacher training should be undertaken to sensitise regular teachers on effective classroom management for CWSN. This training should be recurrent at block/cluster levels and integrated with the on-going in-service teacher training schedules of the SSA. All training modules at the State Council of Educational Research and Training, DIET and the Block Resource Centre (BRC) level should include a suitable component on the education of CWSN.

Further, the RPWD Act, in order to fulfill the mandate of the UNCRPD, casts obligations on the government to establish adequate number of teacher training institutions, to train and employ teachers, including teachers with disabilities, who are qualified in sign language and Braille and those trained in teaching children with intellectual disabilities. It further mandates the training of professionals and staff to support inclusive

¹⁰¹ Section 23, RTE Act.

¹⁰² Section 2, RTE (Amendment) Act, 2017.

¹⁰³ NCTE, Notification dated 23 August 2010 <https://ncte.gov.in/Website/PDF/Minimum-Qualification-2010.pdf>.

¹⁰⁴ Department of Teacher Education, NCERT, 'Syllabus for Bachelor of Education (B. Ed.) Programme' http://www.ncert.nic.in/departments/nie/dtee/activities/pdf/Syllabus_BEEd.pdf.

¹⁰⁵ Section 7, RTE Act.

¹⁰⁶ Section 8, RTE Act.

¹⁰⁷ Section 9, RTE Act.

¹⁰⁸ Andhra Pradesh and Kerala.

education at all levels of school education. This is not reflected in the provision dealing with the training of teachers under the RTE Act.¹⁰⁹ Further, a decade ago, the National Curriculum Framework for Teacher Education, 2009 made a reference to the importance of preparing teachers who can teach in inclusive classrooms and follow an inclusive pedagogy. However, in its NEP, 2016, the Central Government had acknowledged that providing such special training to every teacher would not be cost-effective.¹¹⁰

3.1.3 Special educators

Despite the SSA's endorsement of the inclusive education model, the method of teaching across primary schools continues to be segregated. This is primarily because, in practice, the responsibility of teaching CWSNs is delegated to a separate cadre of "special educators" called "resource persons". The introduction of "special educators" was made through the Rehabilitation Council of India Act, 1992 ("RCI Act"). The primary purpose of the RCI Act is to regulate and monitor the training of rehabilitation professionals and personnel, promote research in rehabilitation and special education. The RCI serves as a certification body for special educators in India. As per the norms prescribed by the RCI, at least one qualified special educator is required for eight students with disabilities. As of March 2018, the central government clarified to Parliament that there were 98,188 special educators registered with the RCI.¹¹¹ Further, in 2016, the MHRD stated that states and union territories had appointed 20,910 resource persons for providing support on inclusive education to regular teachers.¹¹²

Interestingly, the only complaint that private and government special educators and resource persons had in common was the current structure of

obtaining the Continuing Rehabilitation Education (CRE) certificate from the RCI. The CRE certificate renews the licensure of special educators. This has to be done every five years by collecting 100 points through various training sessions. Across states, special educators complained that this process was expensive, cumbersome, and stressful. Government special educators found it difficult to pay for the same out of their pockets. The residential nature of the trainings, limited availability of seats and locations means that this process can be fairly expensive for special educators; "The CRE is a significant financial burden as there is no support from the government." (a government special educator, urban Maharashtra)

While special educators provide education to children with disabilities in special schools, the role of such educators in an inclusive education system remains unclear. The proposed Samagra Shiksha Abhiyaan seeks to clarify this by stating that, "*special educators may be posted at the block or cluster level or as per the requirement and can operate in an itinerant mode, covering a group of schools where CWSN are enrolled so that each child with special needs is adequately covered.*"¹¹³ How this would play out in practice, and whether a special educator will teach alongside a subject teacher recognised by the RTE, is not known as yet.

3.1.4 Working conditions of teachers

Regarding the working conditions of teachers, the RTE Act stipulates that no teacher shall be deployed for any non-educational purposes other than the decennial population census, disaster relief duties or duties relating to elections to the local authority or the State Legislatures or Parliament, as the case may be.¹¹⁴ However, the situation on the ground told a different story. The issue of disproportionate workloads plagues government school teachers and

¹⁰⁹ Section 23, RTE Act.

¹¹⁰ National Education Policy, 2016, MHRD, Government of India.

¹¹¹ "Trained Teachers for Differently Abled Children", Parliamentary Starred Question Number 254, Lok Sabha, answered on 13.0.3.2018, Ministry of Social Justice and Empowerment, <<http://164.100.47.194/loksabha/questions/QResult15.aspx?qref=64441&lsno=16>> accessed 22 December 2019.

¹¹² MHRD, Annual Report 2015-16.

<https://mhrd.gov.in/sites/upload_files/mhrd/files/document-reports/AR_2015-16%20ENGLISH.pdf> accessed on 9 January 2020.

¹¹³ Samagra Shiksha Abhiyan scheme, MHRD, Government of India <<http://samagra.mhrd.gov.in/about.html>> accessed 22 December 2019.

¹¹⁴ Section 27, RTE Act.



head teachers. Most head teachers we met had dual charges – either as head teachers for two schools or were head teachers and held another administrative position. Government school teachers, on the other hand, found themselves as both “accountant and clerk.” As a teacher in rural Madhya Pradesh said, “I do not think of myself as a teacher. I think of myself as a multi-purpose worker.” His list of additional charges and responsibilities included being a booth-level worker in the last election, ensuring data about students’ Aadhaar cards, bank accounts, and Samagra IDs were fed, responding data requests from block and cluster officials, attending teachers’ training, maintaining student-level trackers, student portfolios, organising health camps, books distribution, uniform distribution, conducting household surveys; “there is no peon in this school, so teachers pitch in for school maintenance and beautification.” As several teachers stated, non-teaching responsibilities, high student-teacher ratios, and existence of single-teacher schools prevents them from fulfilling teaching responsibilities towards children without disabilities such that children with disabilities appear to be a burden and a distraction in the classroom.

The working conditions described by block-level resource persons were alarming across states for very similar reasons— disproportionate workload, low salaries and lack of job benefits, and lack of job prestige. The numerous responsibilities of block-level resource persons include conducting surveys to identify children with disabilities, collecting and maintaining records of disabled children in the block, following up with teachers on teaching strategies, conducting school visits, ensuring admission, ensuring smooth examinations and modified assessments, organising parent counseling camps, providing home based education, organising annual medical camps to provide disability certificates, aids and appliances, and tracking and delivering government entitlements. In some places, like in rural Haryana, these resource persons run resource centres to provide special education to children with disabilities in the block.

Given their current assignments and vacancies for these positions, one block resource person may be responsible for covering over 200 schools. As a government official in urban Assam told us, “there are so few of them and the number of children in the districts of Assam is so widespread that it becomes practically difficult for them to reach out to children with disabilities, so the schools will say that nobody has come to us for so long.” The resentment from schools held true for rural Madhya Pradesh as head teachers complained that the resource persons “don’t come, they don’t do anything for the child. They only make sure that they have the child’s account number for transferring the stipend.” The multiple responsibilities contribute to job stress, as resource persons recognise that they are unable to fulfil their responsibilities. As a lone block resource person in rural Haryana covering 165 schools told us, “even when I feel like working here [the centre], I cannot, because there is work on the field. The disproportionate workload is compounded by low pay, no benefits, and out-of-pocket expenditures. According to the resource persons, their travel allowance is too low or non-existent; they are not provided with accident coverage or any overhead for miscellaneous expenses, “I give my all but don’t get enough. I cannot sustain my own children.” (Resource Person, rural Haryana) Across states, several CWSN resource persons highlighted the disparity in resource person salaries and position

across states. According to them, some states pay more and others have created permanent positions for what is currently a six-month or annual contract in most states. Given these circumstances, resource persons felt disrespected and said that they would not recommend special education as a career, “There is a lot of harassment and exploitation in this job.” (Resource Person, rural Haryana)

3.2 Curriculum and pedagogy

The National Curriculum Framework (NCF) 2005 underscores the significance of making curriculums “an inclusive and meaningful experience for children”, stating “this requires a fundamental change in how we think of learners and the process of learning.”¹¹⁵ Even prior to the passage of the RPWD Act, 2016, it was an accepted premise that reimagining the curriculum was critical to developing an inclusive culture in the classroom. This would involve a rehaul of the components of study which consist of the syllabus, textbooks and needed teaching-learning materials, teaching strategies/processes, and assessment and evaluation processes.¹¹⁶ Further, the Department of School Education and Literacy, under the SSA has developed ‘Barkha: A Reading Series for ‘All’ as inclusive learning material in the form of a supplementary early reading series. The Department has stated that its design is based on the principles of inclusion and the concept of Universal Design for Learning (UDL). It also states that ‘Barkha’ seeks to demonstrate how the principles of UDL can guide the design of inclusive features like tactile and high resolution visuals, text in accessible scripts etc.¹¹⁷

Further, in 2016, the MHRD’s School Education and Literacy Department had instructed the National Council for Educational Research and Training (NCERT) to develop learning materials for CWSN.

The MHRD has stated that the NCERT developed two separate handbooks for teachers at the primary and upper primary level. The material deals with curricular adaptations to be done by mainstream teachers in regular classrooms, teaching strategies and adapted evaluations. It contains tips that a regular teacher can adopt in his/her classroom to address the learning needs of all kinds of CWSN. As per the MHRD’s Annual Report, the handbooks seek to present (a) regular teachers with basic understanding about disabilities and their impact on the teaching-learning process; (b) strategies for creating inclusive classrooms from the perspective of sensory, cognitive and intellectual disabilities and; (c) suggestions for Continuous and Comprehensive Evaluation (CCE) in inclusive classrooms.¹¹⁸

Our experiences from talking to various stakeholders told a different story. Special educators, government officials, and teachers across regions found the existing curricula and assessments to be inaccessible for students with disabilities. The absence of clear guidelines around modified assessments was a particular challenge for children with intellectual disabilities, wherein the emphasis for some students might be on functional skills. For some officials, the examination-heavy system seemed to be at odds with inclusive education, “inclusive education doesn’t just mean for them to be there, but also that they learn and pass exams.” (urban Assam) Officials were concerned with assessing learning of children with disabilities, “there is no alternative form of student evaluation for CWSN. This is a problem for the child. The child is included but is not receiving the specialised teaching they need.” (urban Maharashtra) For them, the lack of assessment and student evaluation implied a lack of systemic accountability towards the child. On the other hand, the lack of specialised assessments in an examination-heavy system led teachers to

¹¹⁵ The National Curriculum Framework (NCF) 2005, National Council for Educational Research and Training (NCERT) <<http://www.ncert.nic.in/rightside/links/pdf/framework/english/nf2005.pdf>> accessed 6 January 2019.

¹¹⁶ Anita Jhulka, “Concepts of Curriculum Adaptations”, Curriculum adaptations for children with special needs, Sarva Shiksha Abhiyan, Ministry of Human Resources and Development, February 2016 <https://mhrd.gov.in/sites/upload_files/mhrd/files/document-reports/Confluence.pdf> accessed 30 November 2019.

¹¹⁷ “Barkha Series”, National Council for Educational Research and Training (NCERT), Depart of Elementary Education, MHRD, <<http://www.ncert.nic.in/departments/nie/dee/publication/Barkha.html>>; accessed 30 November 2019.

¹¹⁸ MHRD, Annual Report 2015-16 <https://mhrd.gov.in/sites/upload_files/mhrd/files/document-reports/AR_2015-16%20ENGLISH.pdf> accessed 9 January 2020.

believe that “the child is not learning anything, so there is no point in sending the child to school.” (rural Meghalaya)

Organisations and governments that were successful in modifying the curriculum believed that “any school, any board, any curriculum can be made inclusive.” (rural Maharashtra) There was a strong belief that inclusion did not imply lowering attainment standards for children with disabilities, “Who are we to decide whether they will complete the board or not, let the children decide. They may or may not but why are you deciding in KG that this child has autism so he won’t reach class 12?” (rural Meghalaya)

The challenge of inclusive education extended to teaching strategies in the classroom. Teachers find it difficult to cater to diverse needs in the classroom, and given the large class sizes, they believe that catering to the needs of children with disabilities distracts them from teaching the rest of the class. As a teacher in rural Madhya Pradesh stated, “I am going to tell you what is the practical, ground reality. Inclusive education is a great thought, but the rest of the children will suffer if I only focus on the CWSN in the classroom.” According to him, he had too many students in his classroom to give children with disabilities individualised attention, saying that they “cannot survive” in regular classrooms because they “cannot take what we give”. When asked whether he could design teaching strategies to teach children in the same classroom, there was silence – it was beyond his realm of possibility.

A related problem appears to be catering to children with different disabilities in the same classroom. This was especially true for special educators, who specialise in one disability. For instance, a block resource person in rural Haryana was confident that his B.Ed. Special Education qualification equipped him to teach in special and inclusive settings, “I could teach a class with four visually impaired and 20 general children”. When asked about children with different disability types and general children, “that would probably fail.” He tells us that they receive 5-day multi-purpose disability training, but that is not enough, “if you’ve studied biology and I give you a 5-day training to teach mathematics, will you say it is enough?”

According to teachers and organisations working in inclusive settings, inclusive pedagogy requires appropriate teaching- learning materials, classroom-level infrastructure, support from shadow teachers or special educators, and extensive planning. As a special educator in an inclusive school in rural Maharashtra stated, “you cannot treat it (teaching) as a job – you come and go, it is a lot of work and effort. We have a meeting every Friday to plan for the week, create a theme, think about activities. When I do anything, I have to think about each child— their needs are different.” The teacher was engaged and involved in every aspect of designing the learning experience for the child, “we are trying to maximise use of the five senses for the child. In story time, children watch videos, they do role play. We teach the same thing in different ways. A for Apple— we will draw it, colour it, cut and eat it. We do site visits as well.” In Assam, another organisation aimed at scaling universal design of learning as a pedagogical approach, “the basic concept is that classrooms belong to everyone equally all the time. That’s the idea of inclusive education. So, if you can look at these criteria and keep assessing yourself on these, you can aim for inclusion.”

In both Assam and Maharashtra, the role of special educators for inclusive classrooms was emphasised. The teacher in Maharashtra spoke about the need of a shadow teacher to support modifications of the activities for the disabled child. In Assam, the organisation believed that “special educators can serve as resource persons to help design curricula and strategies. This expertise needs to come from someone who has actually taught children with disabilities.” While the SSA envisions special educators and CWSN resource centres as resource centres for regular teachers, the neglect of inclusive education within the SSA, and the disproportionate workload and adverse working conditions of block level resource persons and teachers allows for little time, resources, or investment towards creating these partnerships.

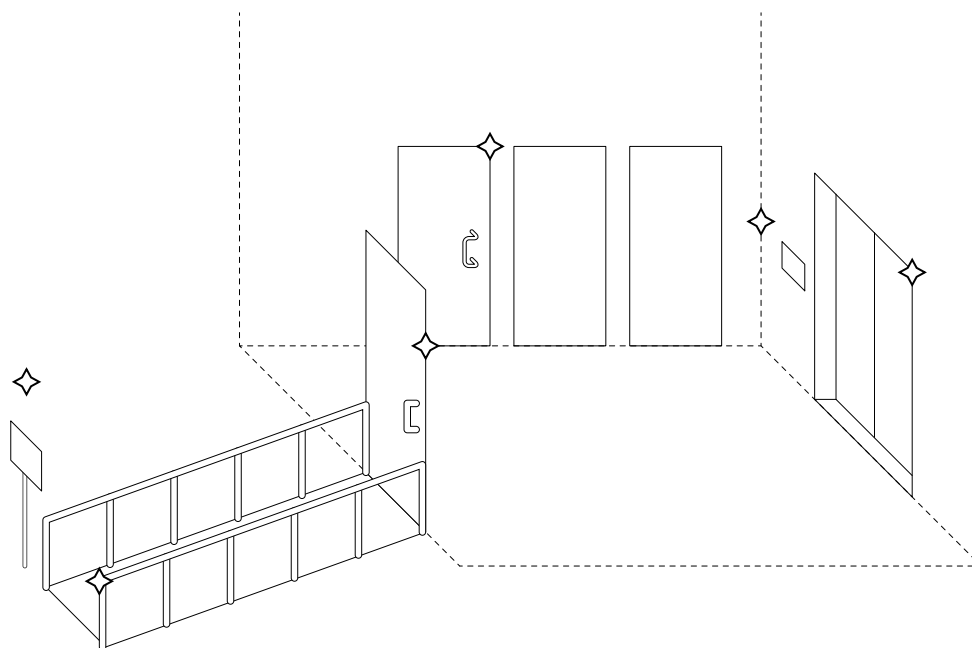

3.3 Infrastructure

The only infrastructural norm under the RTE Act that caters to the needs of children with disabilities is to have school buildings with barrier-free access.¹¹⁹ However, both the RTE Act and the Central RTE Rules fail to explain the meaning of barrier-free access and how it should be implemented. Some state rules, on the other hand, have attempted to prescribe more details. For instance, Kerala State RTE Rules¹²⁰ provide that a school shall receive recognition only if the school provides for barrier-free access and adapted toilets for children with disabilities to use. There is a similar provision in the Haryana State RTE Rules.¹²¹ However, these rules do not cover other aspects of physical accessibility like signages, accessible entrances, corridors, switches and controls, ramps, elevators, accessible desks etc. Nor do they specify the design of outdoor facilities like roads and footpaths that may be needed to access the school.¹²²

Further, to implement the RTE Act in respect of barrier-free access, the SSA framework provides that architectural barriers in schools would have to be removed for easy access and to promote inclusion of CWSN. It further adds that efforts will be taken to provide all kinds of disabled-friendly facilities in schools and educational institutions including not only ramps but also accessible classrooms, toilets, playgrounds, laboratories etc. As per the MHRD, as of 2016, 82.33% schools had 'barrier free' access while 2,12,197 schools had disabled-friendly toilets.¹²³

On the other hand, the RPWD Act stipulates that the building, campus and various facilities should be accessible in educational institutions, and children with disabilities shall be provided reasonable accommodation as per their individual requirements. However, the Act doesn't necessarily adopt a rights-based approach in these respects, but instead directs the government to ensure that the educational institutions be made accessible. The

¹¹⁹ Schedule, RTE Act.

¹²⁰ Kerala RTE Rules, 2011.

¹²¹ Haryana RTE Rules, 2011.

¹²² UNESCO, 'N FOR NOSE: State of the Education Report for India 2019 Children with Disabilities' <http://digitallibrary.in.one.un.org/TempPdfFiles/3793_1.pdf> accessed 9 January 2020.

¹²³ MHRD, Annual Report 2015-16 <https://mhrd.gov.in/sites/upload_files/mhrd/files/document-reports/AR_2015-16%20ENGLISH.pdf> accessed 9 January 2020.

provision related to accessibility under the Central RPWD Rules¹²⁴ prescribes that every public building shall comply with the standards specified under the Harmonised Guidelines and Space Standards for Barrier Free Built Environment for Persons with Disabilities and Elderly Persons.¹²⁵ The MSJE has also launched the Accessible India campaign, under which auditors have been empanelled to audit the accessibility of public buildings and grants-in-aids are released to retrofit these buildings.¹²⁶

Courts have also shed light on the issue of accessibility in educational institutions. In *Disability Rights Group v. Union of India*,¹²⁷ a public interest litigation was filed in reference to accessibility to law colleges, where the Supreme Court “decided to extend the coverage by encompassing all educational institutions.” The Court while emphasising on the provisions of the RPWD Act with respect to accessibility held “to ensure the level playing field, it is not only essential to give necessary education to the persons suffering from the disability, it is also imperative to see that such education is imparted to them in a fruitful manner. That can be achieved only if there is proper accessibility to the buildings where the educational institution is housed as well as to other facilities in the said building.”

Irrespective of these provisions, inaccessibility of government hospitals, offices, and schools was a common issue across states and stakeholders. Head teachers and special educators complained about the poor quality of ramps and lack of disabled-friendly toilets. Parents described how procedures in government offices and hospitals were not designed keeping in mind the needs of children with intellectual disabilities. Additionally, spaces for teacher education and administration were inaccessible for teachers or staff. For example, neither the BRC nor the DIET in rural Madhya Pradesh was wheelchair accessible. The DIET had one ramp leading up to it, but there was no elevator in the multistoried building. While the DIET faculty make attempts to accommodate teachers with

disabilities by placing them on the ground floor, giving the first room, or a quarter on campus, the accommodation was a workaround the existing infrastructural limitations. The architecture of the building precludes access as a right.

Administrators and head teachers complained about lack of clearly demarcated funds for maintaining accessible infrastructure. Where schools or offices were accessible, it was because of the discretion or initiative of that particular official. In rural Haryana, for example, the school principal assigned the closest room to the school gate as the CWSN resource centre and spent grant money to improve the resource room. However, this discretionary power reinforces inaccessibility. A head teacher in rural Madhya Pradesh told us that there was no need for accessible infrastructure if the child was moving about freely in the village where there are no ramps, “I can lift them if needed.” While it sounds abrasive, the head teacher highlights the inaccessibility within communities. Across the nation, as per U-DISE 2016-17, only 62% of schools have ramps and 22% have disabled-friendly toilets. This lack of school level accessibility brings to question access across rural and urban public spaces.

¹²⁴ Rule 15, RPWD Rules.

¹²⁵ Harmonised Guidelines and Space Standards for Barrier Free Built Environment for Persons with Disability and Elderly Persons 2016, Ministry of Urban Development, Government of India <<https://cpwd.gov.in/publication/harmonisedguidelinesreleasedon23rdmarch2016.pdf>> accessed 9 January 2020.

¹²⁶ Accessible India Campaign, MSJE, Government of India <<http://accessibleindia.gov.in/content/>> accessed 9 January 2020.

¹²⁷ (2018) 2 SCC 397

IV

Reimagining Inclusive Education in the RTE Act

The RPWD Act, 2016 and the SSA have sought to enforce the paradigm of inclusive education. However, in its current form, the RTE Act does not, either expressly or implicitly, mandate that the right to primary compulsory education be inclusive. It makes no mention of the term ‘inclusive education’ anywhere in the statute. Also, an assumption of children with disabilities being an afterthought is reinforced by the fact that the RTE Act was enacted prior to the rehaul of the disability laws framework, and hence the approach of “integration” as opposed to “inclusion”. Issues emerging out of some of these policy and structural inconsistencies along with the proposed amendments to the RTE Act to address these issues, have been highlighted below.

Note that the full text of proposed draft amendments to the RTE Act are detailed in Annexure 2 of this Report.

4.1 Making inclusive education the norm; clarifying the models of special schools and home based education

The Problem: Unlike the RPWD Act, the RTE Act does not contain a definition of inclusive education. The norms and standards for schools as provided under the Act are inadequate for the meaningful implementation of inclusive education. The absence of clear norms around inclusive education within the RTE Act is observed in the lack of clarity around provisions for home based education, funding for accessible school infrastructure, and disability inclusive pedagogy, curriculum and assessment. Further, there is a lack of clarity about how school choices of home based education, as given under the RTE Act and special schools as provided by the RPWD Act, reconcile with the idea of inclusive education. Not providing clear pathways for school choice affects access to quality inclusive education for children with disabilities.

Recommendation: The term “inclusive education” must be defined in the RTE Act, in line with the RPWD Act and the proposed policy framework in the Samagra Shiksha Abhiyaan to ensure uniformity in approach and implementation of the mandate of inclusive education across states. The right to free and compulsory education must be broadened to include the right to inclusive education. Consequently, it should also impose corresponding obligations on the government to facilitate inclusive education for children with disabilities aligning with the provisions of the RPWD Act. The Schedule to the RTE Act should be amended to enforce norms and standards for the meaningful implementation of inclusive education. In its current form, due to a lack of implementation of the norms of inclusive education, the right of a disabled child to access primary education at par with other children is not legally enforceable.

The terms ‘special schools’ and ‘home based education’ should be defined in the RTE Act. Further the conditions under which parents of children with disabilities may opt for these education models must be clearly stated while ensuring uniformity across both the RTE and the RPWD Acts.

Proposed amendments to the RTE Act:	<p>(i) The following definition of inclusive education shall be added to the RTE Act:¹²⁸</p> <p>“inclusive education” means a system of education wherein students with and without disabilities learn together and the system of teaching and learning is suitably adapted to meet the learning needs of different types of students with disabilities;</p> <p>(ii) Section 3- ‘Right of child to free and compulsory education’ shall read as-</p>
--	---

¹²⁸ Section 2(gg) shall be added to the RTE Act.

(1) Every child of the age of six to fourteen years, including a child referred to in clause (d) or clause (e) of section 2, shall have the right to free and compulsory education in a neighbourhood school providing **inclusive education** till the completion of his or her elementary education.

(2) A child with disability referred to in clause (ee) of section 2 shall have the same rights to pursue free and compulsory elementary education which children without disabilities have under section 3(1) of this Act:

Provided that a child with benchmark disabilities, as defined in Section 2(ee) B, or a child with high support needs referred to in Section 2(ee)C, or multiple disabilities referred to in Section 2(ee)D of this Act shall have the right to opt for free, compulsory elementary education, up to the age of 18, in a special school.

(iii) Clause (b) of Section 8- 'Duties of appropriate government' shall read as:-

The appropriate government shall--

(b) ensure availability of a neighbourhood school **providing inclusive education** as specified in section 6.

(iv) Schedule to the RTE Act shall be amended to add items on special educators for children with disabilities and their teacher-pupil ratio, definition and norms for "barrier-free access", accessible toilets, playgrounds and library, accessible teaching learning equipment and play materials, games, and sports equipment.

4.2 Defining terms related to categories of disability

The Problem: Despite the PWD Act, 1995 having been repealed, the RTE Act continues to refer to it, even defining terms that are now redundant in light of the new disability rights paradigm. For example, the RTE Act continues to use terms such as “severe disability” and permits children with “severe disability” (and multiple disabilities) to opt for home based education. This provision presents two challenges. For one, the term “severe disability” has now been replaced in the RPWD Act by the term “high support needs”, and two, the RTE Act permits the option for home based education, which is not recognised by the RPWD Act. Not only does this create confusion in the reading of the law, it results in a non-uniform approach in the terminology used in identifying children with disabilities. Identification and certification of children with disabilities is crucial for several reasons - it is linked to access to government provisions such as scholarships and aids and appliances, as well as government planning on disability teacher training.

Reccomendation: The proposed terms in the RTE Act must be redefined to reflect the position of law in the RPWD Act. Further, this change in terminology must be made known to all relevant stakeholders -from teachers to SSA officials- to ensure consistency and sensitivity in the manner of identification of children with disabilities.

Proposed amendments to the RTE Act:	<p>The definition of ‘child with disability’¹²⁹ shall be amended. The new definition shall read as-</p> <p>"child with disability" includes,--</p> <ul style="list-style-type: none">(A) a child, being a person with disability as defined under Section 2(s) of the Rights of Persons with Disabilities Act, 2016;(B) a child, being a person with benchmark disability as defined in Section 2(r) of the Right of Persons with Disabilities Act, 2016;(C) a child, being a person with disability having high support needs as defined in Section 2(t) read with Section 2(l) of the Right of Persons with Disabilities Act, 2016;(D) a child with multiple disabilities, with “multiple disabilities” as defined in Item 5 of the Schedule to the Right of Persons with Disabilities Act, 2016.
--	---

¹²⁹ Section 2(ee), RTE Act.

4.3 Reassigning the governance of special schools to the MHRD

The Problem: The RPWD Act provides the option of special schools for children with benchmark disabilities, however, it does not define special schools. As special schools do not fall within the definition of 'school' under the RTE Act either, they are not in fact considered as schools and not regulated in a similar manner as other schools. The Samagra Shiksha Abhiyan, on the other hand, recognises special schools as important resources for the education of children with disabilities. Our findings indicate that special schools vary immensely in quality of resources, teachers, and accessibility, based on location, management, and funding sources. Additionally, the presence of special schools is often used to push disabled children from inclusive to segregated settings.

Reccomendation: As alluded to above, the definition of 'school' under the RTE Act should be modified to bring special schools within its purview. Further, norms and standards for special schools should be specified under the Act to ensure better regulation across states. This will also ensure that special schools are regulated treated at par with other schools by the MHRD.

Proposed amendments to the RTE Act:

The definition of 'school' shall read as-

- (n) "school" means any recognised school imparting elementary education and includes--
- (i) a school established, owned or controlled by the appropriate government or a local authority;
 - (ii) an aided school receiving aid or grants to meet whole or part of its expenses from the appropriate government or the local authority;
 - (iii) a school belonging to specified category; and
 - (iv) an unaided school not receiving any kind of aid or grants to meet its expenses from the appropriate government or the local authority;
 - (v) a special school**

The current Schedule to the RTE Act should be amended to incorporate principles of inclusivity and universal design in laying down norms and standards for schools.

Schedule II should be added for laying down norms and standards for special schools.

4.4 Rethinking teacher role and training

The Problem: General teachers and special educators have a pivotal role in ensuring inclusive, equitable, safe, and enriching classroom environments for children with disabilities. Our field visits uncovered several challenges teachers experience in attaining this goal. In terms of working conditions, teachers experience disproportionate workloads due to teacher vacancies, class sizes, and non-teaching responsibilities. With regard to pedagogy, teachers complain about the lack and inadequacy of existing training programs to include children with disabilities in their classrooms. Special educators face similar challenges around their working conditions and pedagogical practices. They tend to be contractual hires who do not get sufficient salaries, and find that they are being exploited in the existing system.

Reccomendation: Special educators must be treated at par with the category of teachers recognised under the RTE Act and their conditions of service shall be similar to recognised teachers. The element of training of teachers in inclusive education shall be highlighted more explicitly as part of minimum qualifications in the Act or the rules prescribed under it.

Proposed amendments to the RTE Act:

Section 23- ‘Qualifications for appointment and terms and conditions of service of teachers’ shall read as-

(1) Any person possessing such minimum qualifications, as laid down by academic authorities,¹³⁰ authorised by the Central Government, by notification, shall be eligible for appointment as a teacher or a **special educator**.

(2) Where a State does not have adequate institutions offering courses or training in teacher education, or teachers possessing minimum qualifications as laid down under sub-section (1) are not available in sufficient numbers, the Central Government may, if it deems necessary, by notification, relax the minimum qualifications required for appointment as a teacher, for such period, not exceeding five years, as may be specified in that notification:

¹³⁰ While NCTE can continue to be the academic authority for laying down minimum qualifications for regular teachers, the RCI can be notified as an academic authority for special educators under the Act.

Provided that a teacher who, at the commencement of this Act, does not possess minimum qualifications as laid down under sub-section (1), shall acquire such minimum qualifications within a period of five years, **including training in inclusive education.**

Provided further that every teacher appointed or in position as on the 31st March, 2015, who does not possess minimum qualification laid down under sub-section (1), shall acquire such minimum qualifications within a period of four years from the date of commencement of the Right of Children to Free and Compulsory Education (Amendment) Act, 2017.

(3) The salary and allowances payable to, and the terms and conditions of service of teachers **and special educators** shall be such as may be prescribed

Way Forward

The above recommendations aim at the textual harmonisation of the RTE Act and the RPWD Act with respect to the issues identified. However, two of the issues identified above need further attention. One, the role played by special educators in the inclusive education model and, two, the lack of clarity with respect to the position of special schools in the inclusive education framework. While we have briefly discussed these, we aim to take a deep dive into these issues by means of our next research study focusing on special educators and special schools to take this discussion further.



Annexures

Annexure 1

Table 1: Details of stakeholders interviewed across different states

Participants

- Government Officials
- Teachers/Educators
- Teacher Trainers
- Parents
- CSO members

Demography

- Rural
- Urban

State ▶	School Type(s)	Field Site(s)	Participants
Haryana (North)			
	Government school Private special school	2 Blocks in one district	<ul style="list-style-type: none"> 1 district education official 1 district CWSN resource person 4 block CWSN resource persons 1 private special school leader 1 private school special educator 2 government school teachers 1 parent of disabled child in government school
Maharashtra (West)			
	Government special school Government school Private special school	2 Cities	<ul style="list-style-type: none"> 3 state level government officials 8 block CWSN resource persons 2 government special school leaders 1 government special educator 2 private special educators 6 parents of children with disabilities in government special school 3 parents of children with disabilities in private special school 7 CSO members
	Private inclusive school	1 District	<ul style="list-style-type: none"> 2 private inclusive school leaders 1 private special educator 2 parents of children without disabilities in private inclusive school
Madhya Pradesh (Central)			
	Government school	2 Blocks in one district	<ul style="list-style-type: none"> 1 block resource coordinator 11 block CWSN resource persons 3 government school teachers 1 government school leader 3 DIET faculty 1 parent of child with disabilities in government school
Meghalaya (North East)			
	Government School	1 Block in one district	<ul style="list-style-type: none"> 1 block resource coordinator 2 block CWSN resource persons 2 government school teachers 2 parents/guardians of children with disabilities in government school 1 CSO member
Assam (North East)			
	Government School Private School	1 City	<ul style="list-style-type: none"> 1 State level Government Official 2 district level government officials 1 cluster resource coordinator 1 block CWSN Resource Person 2 CSWN Resource Persons 1 government school leader 2 government school teachers 1 CSO member
	Government School Private School	1 Block in one district	<ul style="list-style-type: none"> 3 government school teachers 1 private school leader 1 private school teacher 1 parent of child with disability in private school 1 parent of child with disability who is below 6 years 1 parent of child who cannot go to school

Annexure 2

Proposed Amendments to the Right of Children to Free and Compulsory Education Act, 2009 to guarantee a right to inclusive education

Section 2(ee)

“child with disability” includes,--
(A) a child with “disability” as defined in clause (i) of section 2 of the Persons with Disabilities (Equal Opportunities, Protection of Rights and Full Participation) Act, 1995 (1 of 1996),
(B) a child, being a person with disability as defined in clause (j) of section 2 of the National Trust for Welfare of Persons with Autism, Cerebral Palsy, Mental Retardation and Multiple Disabilities Act, 1999 (44 of 1999);
(C) a child with “severe disability” as defined in clause (o) of section 2 of the National Trust for Welfare of Persons with Autism, Cerebral Palsy, Mental Retardation and Multiple Disabilities Act, 1999 (44 of 1999).

Substitute section 2(ee) with the following:--
“child with disability” includes,--
(A) a child, being a person with disability as defined under Section 2(s) of the Rights of Persons with Disabilities Act, 2016 (49 of 2016);
(B) a child, being a person with benchmark disability as defined in Section 2(r) of the Right of Persons with Disabilities Act, 2016 (49 of 2016);
(C) a child, being a person with disability having high support needs as defined in Section 2(t) read with Section 2(l) of the Right of Persons with Disabilities Act 2016 (49 of 2016);
(D) a child with multiple disabilities, with “multiple disabilities” as defined in Item 5 of the Schedule to the Right of Persons with Disabilities Act 2016 (49 of 2016).

Add section 2(ga)

Proposing a new provision

Define the term “home-based education”.

Add Section 2(gb)

Proposing a new provision

“inclusive education” means inclusive education as defined in section 2(m) of the Rights of Persons with Disabilities Act, 2016;

Section 2(n)

(n) “school” means any recognised school imparting elementary education and includes--
(i) a school established, owned or controlled by the appropriate government or a local authority;
(ii) an aided school receiving aid or grants to meet whole or part of its expenses from the appropriate government or the local authority;
(iii) a school belonging to specified category; and
(iv) an unaided school not receiving any kind of aid or grants to meet its expenses from the appropriate Government or the local authority;

In section 2(n)--
After sub-clause (iv), the following sub-clause shall be inserted:--
(v) a special school as defined in Section 2(oa) of this Act.

Existing provision in RTE Act

Proposed Amendment

Add Section 2(oa)

Proposing a new provision

Define the term “special school”.

Section 3

(1) Every child of the age of six to fourteen years, including a child referred to in clause (d) or clause (e) of section 2, shall have the right to free and compulsory education in a neighbourhood school till the completion of his or her elementary education.] 2[***]

(3) A child with disability referred to in sub-clause (A) of clause (ee) of section 2 shall, without prejudice to the provisions of the Persons with Disabilities (Equal Opportunities, Protection of Rights and Full Participation) Act, 1995, and a child referred to in sub-clauses (B) and (C) of clause (ee) of section 2, have the same rights to pursue free and compulsory elementary education which children with disabilities have under the provisions of Chapter V of the Persons with Disabilities (Equal Opportunities, Protection of Rights and Full Participation) Act, 1995(1 of 1996):

Provided that a child with “multiple disabilities” referred to in clause (h) and a child with “severe disability” referred to in clause (o) of section 2 of the National Trust for Welfare of Persons with Autism, Cerebral Palsy, Mental Retardation and Multiple Disabilities Act, 1999(44 of 1999) may also have the right to opt for home based education.

In section 3--

(1) in sub-section (1), after the word “school”, the words “providing inclusive education” shall be inserted.

(2) in sub-section (3), the words “sub-clause (A)” shall be omitted. The words “without prejudice to the provisions of the Persons with Disabilities (Equal Opportunities, Protection of Rights and Full Participation) Act, 1995, and a child referred to in sub-clauses (B) and (C) of clause (ee) of section 2, have the same rights to pursue free and compulsory elementary education which children with disabilities have under the provisions of Chapter V of the Persons with Disabilities (Equal Opportunities, Protection of Rights and Full Participation) Act, 1995(1 of 1996)” shall be substituted with “have the same rights to pursue free and compulsory elementary education as children without disabilities under Section 3(1) of this Act”.

(3) Proviso to sub-section (3) shall be substituted with “provided that a child with benchmark disabilities as defined in Section 2(ee)(B), a child with high support needs referred to in Section 2(ee)(C), and a child with multiple disabilities referred to in Section 2(ee)(D) of this Act shall have the right to opt for free, compulsory elementary education, up to the age of 18, in a special school or neighbourhood school of their choice”.

Second proviso shall be added: “It is further provided that a child with high support needs referred to in Section 2(ee)(C) or multiple disabilities referred to in Section 2(ee)(D) of this Act shall have the right to opt for free, compulsory elementary education, up to the age of 18, in a special school or neighbourhood school or through a home based education system of their choice.”

Existing provision in RTE Act

Proposed Amendment

Section 8

The appropriate government shall--

(a) provide free and compulsory elementary education to every child:

Provided that where a child is admitted by his or her parents or guardian, as the case may be, in a school other than a school established, owned, controlled or substantially financed by funds provided directly or indirectly by the appropriate government or a local authority, such child or his or her parents or guardian, as the case may be, shall not be entitled to make a claim for reimbursement of expenditure incurred on elementary education of the child in such other school.

Explanation--The term "compulsory education" means obligation of the appropriate government to--

- (i) provide free elementary education to every child of the age of six to fourteen years; and
- (ii) ensure compulsory admission, attendance and completion of elementary education by every child of the age of six to fourteen years;
- (b) ensure availability of a neighbourhood school as specified in section 6;
- (c) ensure that the child belonging to weaker section and the child belonging to disadvantaged group are not discriminated against and prevented from pursuing and completing elementary education on any grounds;
- (d) provide infrastructure including school building, teaching staff and learning equipment;
- (e) provide special training facility specified in section 4;
- (f) ensure and monitor admission, attendance and completion of elementary education by every child;
- (g) ensure good quality elementary education conforming to the standards and norms specified in the Schedule;
- (h) ensure timely prescribing of curriculum and courses of study for elementary education; and
- (i) provide training facility for teachers.

In section 8--

(1) in clause (b), after the word "school", the words "providing inclusive education" shall be inserted.

Existing provision in RTE Act

Proposed Amendment

Section 15

A child shall be admitted in a school at the commencement of the academic year or within such extended period as may be prescribed: Provided that no child shall be denied admission if such admission is sought subsequent to the extended period: Provided further that any child admitted after the extended period shall complete his studies in such manner as may be prescribed by the appropriate government.

In section 15--
After the second proviso, the following proviso shall be inserted:-
“Provided further that no child shall be denied admission on the ground of absence of a disability certificate”.

Section 19

(1) No school shall be established, or recognised, under section 18, unless it fulfils the norms and standards specified in the Schedule.
(2) Where a school established before the commencement of this Act does not fulfill the norms and standards specified in the Schedule, it shall take steps to fulfill such norms and standards at its own expenses, within a period of three years from the date of such commencement.
(3) Where a school fails to fulfill the norms and standards within the period specified under subsection (2), the authority prescribed under sub-section (1) of section 18 shall withdraw recognition granted to such school in the manner specified under sub-section (3) thereof.
(4) With effect from the date of withdrawal of recognition under sub-section (3), no school shall continue to function.
(5) Any person who continues to run a school after the recognition is withdrawn, shall be liable to fine which may extend to one lakh rupees and in case of continuing contraventions, to a fine of ten thousand rupees for each day during which such contravention continues.

In section 19--
(1) In sub-section (1), after the word “school”, the words “excluding schools specified under sub-clause (v)” shall be inserted and the word “Schedule” shall be substituted with the words “First Schedule”.
(2) After sub-section (1), the following sub-section shall be inserted:-
“(1a) No school specified under sub-clause 2(n)(v) shall be established, or recognised under section 18, unless it fulfils the norms and standards specified in the Second Schedule”.

Existing provision in RTE Act

Proposed Amendment

Section 23

(1) Any person possessing such minimum qualifications, as laid down by an academic authority, authorised by the Central Government, by notification, shall be eligible for appointment as a teacher.

(2) Where a State does not have adequate institutions offering courses or training in teacher education, or teachers possessing minimum qualifications as laid down under sub-section (1) are not available in sufficient numbers, the Central Government may, if it deems necessary, by notification, relax the minimum qualifications required for appointment as a teacher, for such period, not exceeding five years, as may be specified in that notification:

Provided that a teacher who, at the commencement of this Act, does not possess minimum qualifications as laid down under sub-section (1), shall acquire such minimum qualifications within a period of five years. Provided further that every teacher appointed or in position as on the 31st March, 2015, who does not possess minimum qualification laid down under sub-section (1), shall acquire such minimum qualifications within a period of four years from the date of commencement of the Right of Children to Free and Compulsory Education (Amendment) Act, 2017.

(3) The salary and allowances payable to, and the terms and conditions of service of teachers shall be such as may be prescribed.

In section 23--

(1) In sub-section (1), the words “academic authority” shall be substituted with “academic authorities” and after the word “teacher”, the words “which includes a special educator” shall be inserted.

(2) In the first proviso to sub-section (2), after the word “years”, the words “including training in inclusive education” shall be inserted.

(3) In sub-section (3), after the word teacher, the words “including special educators” shall be inserted.

Section 26

The appointing authority, in relation to a school established, owned, controlled or substantially financed by funds provided directly or indirectly by the appropriate government or by a local authority, shall ensure that vacancy of teacher in a school under its control shall not exceed ten per cent of the total sanctioned strength.

In section 26--

After the word “teacher”, the words “and special educators” shall be inserted.

Existing provision in RTE Act

Proposed Amendment

Section 29

(1) The curriculum and the evaluation procedure for elementary education shall be laid down by an academic authority to be specified by the appropriate Government, by notification.

(2) The academic authority, while laying down the curriculum and the evaluation procedure under sub-section (1), shall take into consideration the following, namely:--

- (a) conformity with the values enshrined in the Constitution;
- (b) all round development of the child;
- (c) building up child's knowledge, potentiality and talent;
- (d) development of physical and mental abilities to the fullest extent;
- (e) learning through activities, discovery and exploration in a child friendly and child centered manner;
- (f) medium of instructions shall, as far as practicable, be in child's mother tongue;
- (g) making the child free of fear, trauma and anxiety and helping the child to express views freely;
- (h) comprehensive and continuous evaluation of child's understanding of knowledge and his or her ability to apply the same.

In section 29--

In sub-section (2), after clause (c), the following clauses shall be inserted:

- (ca) needs of children with disabilities;
- (cb) universal design for learning;

Schedule

Please refer to the Schedule to the RTE Act

The word "Schedule" shall be substituted with the words "first schedule".

The following items shall be inserted in the Schedule:

- Item 1 (a): Add a teacher aid for children with disability
- (b): Add "(1)(3)(ii)(D) "Special Instructor"
- Item 2 (ii): Define "barrier-free access"
- (iii) Toilets shall be accessible for children with disability
- (vi) Playground shall be accessible for children with disability
- Item 5: Teaching-learning equipment shall be available and accessible for children with disabilities.
- Item 6: Library shall be accessible for children with disability
- Item 7: Play material, games and sports equipment shall be accessible for children with disabilities.

Add Second Schedule

Proposing a new provision (Second Schedule to the Act)

Insert norms and standards for special schools.

■ Existing provision in RTE Act

■ Proposed Amendment

For any queries and clarifications regarding
this report, please contact
shreya.shrivastava@vidhilegalpolicy.in

www.vidhilegalpolicy.in

Vidhi Centre for Legal Policy
D-359, Defence Colony
New Delhi - 110024
011-43102767/43831699
vclp@vidhilegalpolicy.in

Design: Kunal Agnihotri